



Introduction

Contents

Specifications	2
Straight Cable Plugs	3
Right Angle Cable Plugs	4
Straight Cable Jacks	6
Bulkhead Cable Jacks	7
Panel Cable Jacks	10
Bulkhead Receptacles	11
Panel Receptacles	12
PCB Receptacles	12
Accessories	13
Adapters Within Series	14

BNC Mating Interface Options

Standard—2-Stud mating

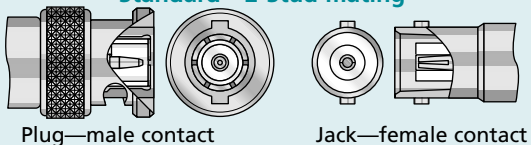

Polarized—2-Stud mating

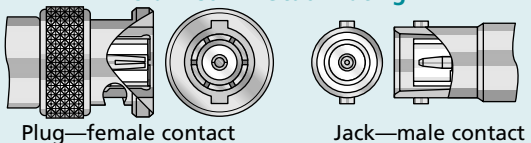

Anti-Rock—3-Stud mating

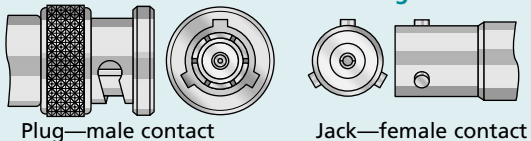

Anti-Rock—4-Stud mating

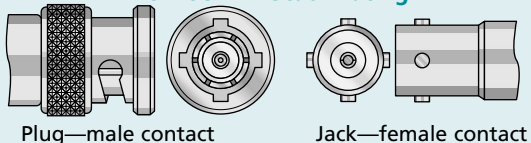

BNC series connectors are general-purpose, low-cost miniature connectors, with a frequency range of DC–4 GHz and 50Ω impedance, designed to MIL-PRF-39012 requirements.

Their bayonet-type interface provides quick mating and unmating, and prevents accidental disconnection from pulling forces on the cable.

Automatic BNC cable connectors are available with nine standard cable attachment types for flexible and semi-rigid cable:

- **Standard and Improved Wedge-Lock;** our patented, quick assembly method for flexible cable incorporating a captive center contact, only three parts to handle, and requiring no special tools.
- **V-Groove** clamping with captive or noncaptive contacts for flexible cable, requiring no special tools for assembly.
- **Econo-Crimp** types with captive or noncaptive contacts for flexible cable, providing small size, light weight, and rapid assembly using standard, commercially-available crimp tools.
- **X-Crimp** with captive contacts for flexible cable, providing rugged, high-strength cable attachment and quick assembly.
- **Wedge-Eze** for flexible cable is our unique system featuring quick assembly, color coding by cable size, and field replaceability. Rapidly assembled with hand or automated tooling, or without special tools.
- **Solder-Clamp** assembly for semi-rigid cable requires no special tools and allows for re-orientation of the connector after assembly to easily conform to system layout. Collet type clamping for solderless attachment of semi-rigid cable is also available.

Download the **glossary** file from our website for details on all cable attachment types.

Many of our BNC connectors are qualified to MIL-PRF-39012, and adapters to MIL-PRF-55339. Some of our M39012 QPL cable connectors are available with your choice of Wedge-Lock, V-Groove, or Econo-Crimp cable attachment. See our website for information on our BNC QPL connectors and adapters.

The versatility of BNC series of RF connectors is enhanced by Automatic's ability to provide a wide range of alternate constructions and configurations to meet virtually any system requirements. Contact us with your requirements for custom configurations, such as:

- **Polarized mating interfaces** with reversed contacts and insulators to prevent accidental mating of incompatible circuits. (see illustration at left).
- **Anti-Rock mating interfaces** with three-stud or four-stud designs. (see illustration at left).
- **Twinaxial and Triaxial** versions of all types are available, with anti-rock interfaces to minimize triboelectric noise in sensitive systems.
- **75 ohm impedance** versions are available in all BNC configurations.
- BNC connectors with **Aluminum bodies** can provide significant weight savings.

Notes:

The standard BNC connectors in this section have nickel-plated bodies and gold-plated center contacts. All are available with other platings if required.

Drawings in this section are approximately actual size; some drawing proportions may be altered to better illustrate details.

Drawing dimensions are in inches (millimeters), based on one inch = 25.4 mm.

Interface Dimensions and Specifications

Interface Dimensions (MIL-STD-348)

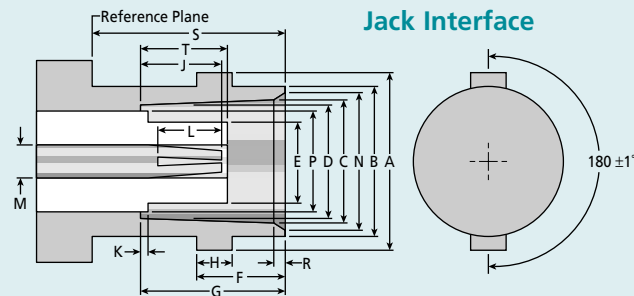

Dim.	Min.	Max.
A	.432 (10.9)	.426 (11.1)
B	.378 (9.6)	.382 (9.7)
C	.327 (8.3)	.333 (8.5)
D	.319 (8.1)	.321 (8.2)
E	—	.186 (4.7)
F	.204 (5.2)	.208 (5.3)
G	.327 (8.3)	.335 (8.5)
H	.075 (1.9)	.081 (2.1)
J	.186 (4.7)	.206 (5.2)

Dim.	Min.	Max.
K	—	.006 (.2)
L	.195 (5.0)	—
M	.081 (2.1)	.087 (2.2)
N	.346 (8.8)	.356 (9.0)
P	—	.256 (6.5)
R	.015 (.4)	.030 (.8)
S	.414 (10.5)	—
T	.188 (4.8)	.208 (5.3)

Plug Interface

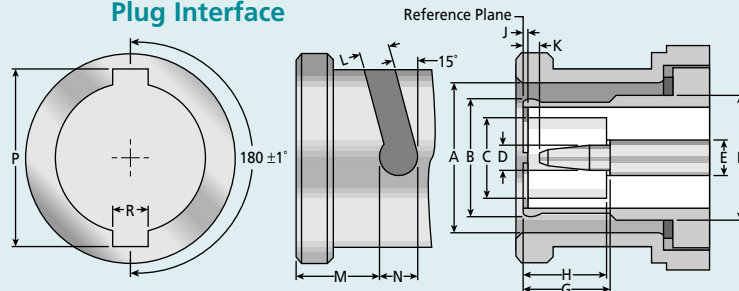

Dim.	Min.	Max.
A	.385 (9.8)	.390 (9.9)
B	To meet gauge test	
C	.190 (4.8)	—
D	.052 (1.3)	.054 (1.4)
E	.081 (2.1)	.087 (2.2)
F	—	.322 (8.2)
G	.210 (5.3)	.230 (5.8)
H	.208 (5.3)	.228 (5.8)
J	.006 (.2)	—

Dim.	Min.	Max.
K	.003 (.1)	—
L	.091 (2.3)	.097 (2.5)
M	.180 (4.6)	.184 (4.7)
N	.124 (3.2)	—
P	.463 (11.8)	.473 (12.0)
R	.091 (2.3)	.097 (2.5)

Specifications (MIL-PRF-39012; MIL-STD-202 test methods)

Electrical:

Frequency Range: DC–4 GHz. **Impedance:** 50 ohms. **Voltage Rating:** 500 V RMS
Insulation Resistance: 5,000 megohms min. (Method 302, condition B).
Dielectric Withstanding Voltage: 1,500 V RMS min. (Method 301).
Contact Resistance: Center Contact—1.5 milliohms max. initial; 2.0 milliohms max. after environmental tests. Outer Contact—.2 milliohms max. Braid to Body—.1 milliohms max.

RF High Potential: 1,000 V RMS min. @ 5–7.5 MHz.

VSWR: Varies with configuration; see MIL-PRF-39012 specification sheets.

RF Leakage: -55 dB min. @ 2–3 GHz.

Insertion Loss: Varies with configuration; see MIL-PRF-39012 specification sheets.

Environmental:

Vibration: Method 204, Condition B. **Shock:** Method 213, condition G.

Corona Level: 375 V min. @70,000 feet.

Moisture Resistance: Method 106; insulation resistance >200 megohms within 5 minutes of removal from humidity.

Thermal Shock: Method 107, condition B, high temperature 85° C.

Corrosion: Method 101, condition B.

Mechanical:

Force to Engage and Disengage: Longitudinal force, 3 pounds max.
Torque, 2.5 inch-pounds max.

Coupling Nut Retention: 100 pounds.

Cable Retention: Dependent upon cable; see MIL-PRF-39012 specification sheet.

Mating Characteristics: Per MIL-STD-348.

Durability: 500 mating cycles @ 12 cycles per minute max.

Center Contact Retention: 6 pounds min. axial force (captive-contact types).

Materials (unless otherwise noted):

Male Center Contacts: Brass. **Female Center contacts:** Beryllium copper.

Bodies and Other Metal Parts: Brass. **Crimp Sleeves:** Annealed brass or soft copper

Insulators: Teflon (TFE). **Gaskets:** Silicone rubber.

Plating:

Center Contacts: Gold plated per current MIL-PRF-39012 requirements.

Other Metal Parts: Standard items, nickel plated per QQ-N-290; M39012 and M55339 QPL items, silver plated per current MIL-PRF-39012 or MIL-PRF-55339 requirements.



Straight Cable Plugs

Cable Group	Wedge-Lock and V-Groove				
	Wedge-Lock		V-Groove		Figure
	Standard	Improved	Non-Captive Contact	Captive Contact	
CF-1	K801-B1800W	10-01001-016	K011-B1000B	K011-B1100D	1
CF-2	K819-B1800W	10-01001-017	K025-B1000B	K025-B1100D	1
CF-3, 4	K847-B1800W	10-01001-012	K039-B1000B	K039-B1100D	1
CF-5, 6	K101-B1800	10-01001-019*	K100-B1000A†	10-01014-006*	1
CF-7, 8	K151-B1800	10-01001-021*	K150-B1000A†	10-01014-007*	1
CF-9	K121-B1800	10-01001-020*	K120-B1000A†	K121-B1100A*	1
CF-22	K301-B1800D	10-01001-023	K300-B1000A†	K301-B1100A	2
CF-36	K825-B1800W	10-01001-018	K825-B1000A	K825-B1100A	1

Cable Group	Econo-Crimp and X-Crimp				
	Econo-Crimp			X-Crimp	
	Non-Captive Contact	Captive Contact	Figure		Figure
CF-2	K919-B1900	10-01077-021	3	K919-B1900F	4
CF-3, 4	K947-B1900	10-01009-012*	3	K947-B1900F	4
CF-5	K980-B1900	10-01009-014*	3	K980-B1900F	4
CF-6	K988-B1900	10-01009-015*	3	K988-B1900F	4
CF-7	K998-B1900	10-01009-016*	3	K998-B1900F	4
CF-8	K999-B1900	10-01009-017*	3	K999-B1900F	4
CF-9	K958-B1900	10-01009-013*	3	K958-B1900F	4
CF-36	K925-B1900	10-01077-022	3	K925-B1900F	4

Cable Group	Wedge-Eze	
	Non-captive Contact	
	Part Number	Figure
CF-5, 6	K100-B1600	5
CF-7, 8	K150-B1600	5

Cable Group	Solder-Clamp (Semi-Rigid Cable)	
	Captive Contact	
	Part Number	Figure
SR-5	Contact Factory	1
SR-6	Contact Factory	1

- See page 15 for cable groups. Most types available for other cables not shown above.
- All items have nickel-plated bodies and gold-plated contacts (solder-clamp types also have gold-plated solder ferrules). All items are also available with silver-plated bodies.
- *Available in MIL-PRF-39012/16 QPL version.
- †Available as UG type.

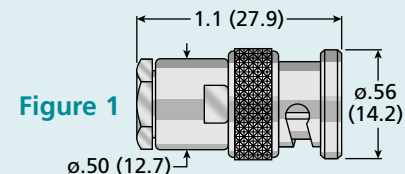

Figure 1

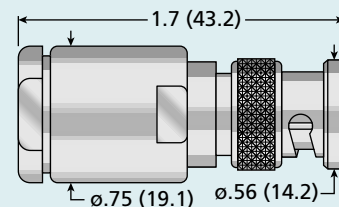

Figure 2

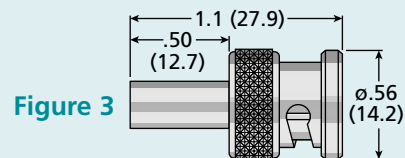

Figure 3

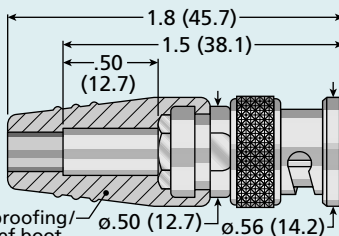

Figure 4

Weatherproofing/
strain relief boot

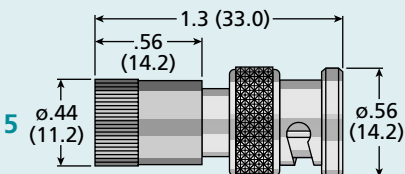

Figure 5

Right Angle Plugs—Mitered Body

Cable Group	Wedge-Lock and V-Groove				
	Wedge-Lock		V-Groove		Figure
	Standard	Improved	Non-Captive Contact	Captive Contact	
CF-1	K801-B2800A	10-10001-003	K011-B2000N	K011-B2100N	1
CF-2	K819-B2800A	10-10001-004	K025-B2000N	K025-B2100N	1
CF-3, 4	K847-B2800A	10-10001-006	K039-B2000N	K039-B2100N	1
CF-5, 6	K101-B2800A	10-10001-007*	K100-B2000N†	10-01004-003*	1
CF-7, 8	K151-B2800A	10-10001-009*	K150-B2000N	10-01004-004*	1
CF-9	K121-B2800A	10-10001-008	K120-B2000N	K121-B2100N	1
CF-22	K301-B2800A	10-10001-011	K300-B2000N	K301-B2100N	2
CF-36	K825-B2800A	10-10001-005	K825-B2000N	K825-B2100N	1

Cable Group	Econo-Crimp and X-Crimp				
	Econo-Crimp			X-Crimp	
	Non-Captive Contact	Captive Contact	Figure		Figure
CF-2	K919-B2900S	10-10011-000	3	K919-B2900F	4
CF-3, 4	K947-B2900S	10-10005-008*	3	K947-B2900F	4
CF-5	K980-B2900	10-10005-010*	3	K980-B2900F	4
CF-6	K988-B2900	10-10005-011*	3	K988-B2900F	4
CF-7	K998-B2900	10-10005-012	3	K998-B2900F	4
CF-8	K999-B2900	10-10005-013	3	K999-B2900F	4
CF-9	K958-B2900	10-10005-009	3	K958-B2900F	4
CF-36	K925-B2900S	10-10011-001	3	K925-B2900F	4

Cable Group	Solder-Clamp (Semi-Rigid Cable)	
	Captive Contact	
	Part Number	Figure
SR-5	Contact Factory	1
SR-6	Contact Factory	1

Cable Group	Wedge-Eze	
	Non-captive Contact	
	Part Number	Figure
CF-5, 6	K100-B2600	5
CF-7, 8	K150-B2600	5

- See page 15 for cable groups. Most types available for other cables not shown above.
- All items have nickel-plated bodies and gold-plated contacts (solder-clamp types also have gold-plated solder ferrules). All items are also available with silver-plated bodies.
- *Available in MIL-PRF-39012/20 QPL version.
- †Available as UG type.

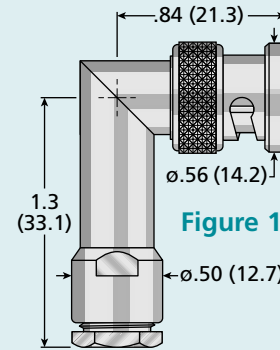

Figure 1

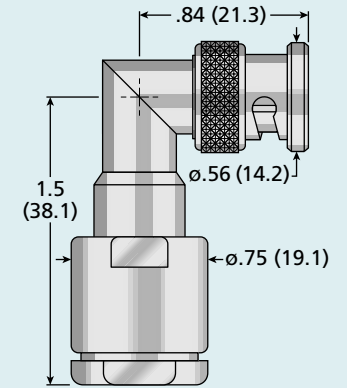

Figure 2

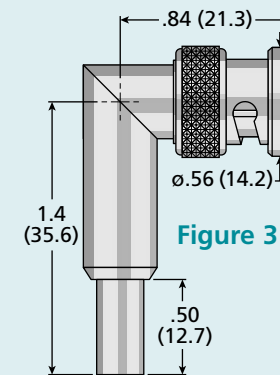

Figure 3

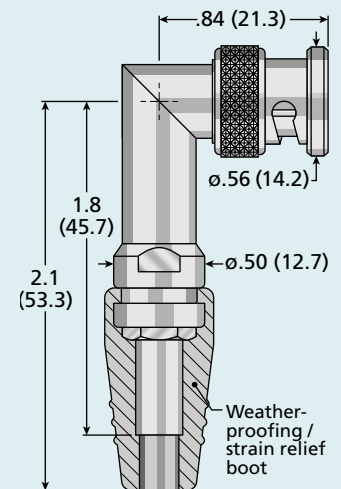

Figure 4

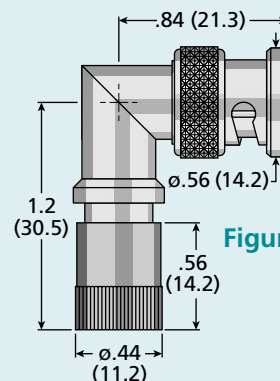

Figure 5

Right Angle Plugs—Cube Body with Access Cap

Cable Group	Wedge-Lock and V-Groove		
	Wedge-Lock	V-Groove	Figure
	Standard	Captive Contact	
CF-1	K801-B2800W	K011-B2100A	1
CF-2	K819-B2800W	K025-B2100A	1
CF-3, 4	K847-B2800W	K039-B2100A	1
CF-5, 6	K101-B2800W	K101-B2100A	1
CF-7, 8	K151-B2800W	K151-B2100A	1
CF-9	K121-B2800W	K121-B2100A	1
CF-36	K825-B2800W	K825-B2100A	1

Cable Group	X-Crimp	
	Captive Contact	
	Part Number	Figure
CF-2	K919-B2900H	2
CF-3, 4	K947-B2900H	2
CF-5	K980-B2900H	2
CF-6	K988-B2900H	2
CF-7	K998-B2900H	2
CF-8	K999-B2900H	2
CF-9	K958-B2900H	2
CF-36	K925-B2900H	2

Cable Group	Solder-Clamp (Semi-Rigid Cable)	
	Captive Contact	
	Part Number	Figure
SR-5	Contact Factory	1
SR-6	Contact Factory	1

- See page 15 for cable groups. Most types available for other cables not shown above.
- All items have nickel-plated bodies and gold-plated contacts (solder-clamp types also have gold-plated solder ferrules). All items are also available with silver-plated bodies.

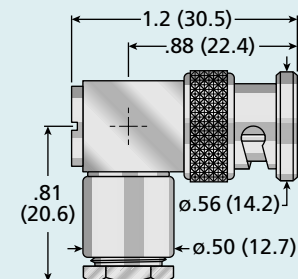

Figure 1

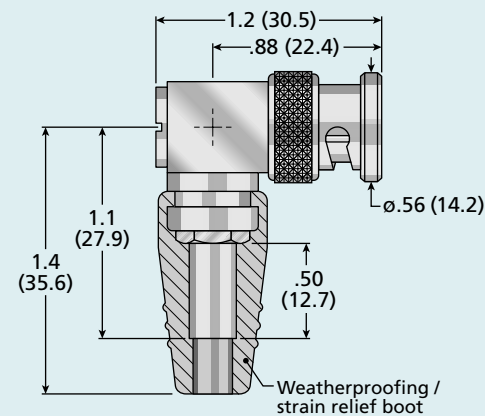

Figure 2

Straight Cable Jacks

Cable Group	Wedge-Lock and V-Groove				
	Wedge-Lock		V-Groove		Figure
	Standard	Improved	Non-Captive Contact	Captive Contact	
CF-1	K801-B3800	10-16001-007	K011-B3000A	K011-B3100A	1
CF-2	K819-B3800	10-16001-008	K025-B3000A	K025-B3100A	1
CF-3, 4	K847-B3800	10-16001-010	K039-B3000A	K039-B3100A	1
CF-5, 6	K101-B3800	10-16001-011*	K100-B3000A†	10-16003-006*	1
CF-7, 8	K151-B3800	10-16001-013*	K150-B3000A†	10-16003-007*	1
CF-9	K121-B3800	10-16001-012*	K120-B3000A	K121-B3100A*	1
CF-22	K301-B3800	10-16001-015	K300-B3000A	K301-B3100A	2
CF-36	K825-B3800	10-16001-009	K825-B3000A	K825-B3100A	1

Cable Group	Econo-Crimp and X-Crimp				
	Econo-Crimp			X-Crimp	Figure
	Non-Captive Contact	Captive Contact	Figure		
CF-2	K919-B3900S	10-16007-000	3	K919-B3900F	4
CF-3, 4	K947-B3900S	10-16005-010*	3	K947-B3900F	4
CF-5	K980-B3900	10-16005-012*	3	K980-B3900F	4
CF-6	K988-B3900	10-16005-013*	3	K988-B3900F	4
CF-7	K998-B3900	10-16005-014*	3	K998-B3900F	4
CF-8	K999-B3900	10-16005-015*	3	K999-B3900F	4
CF-9	K958-B3900	10-16005-011*	3	K958-B3900F	4
CF-36	K925-B3900S	10-16007-001	3	K925-B3900F	4

Cable Group	Wedge-Eze	
	Non-captive Contact	
	Part Number	Figure
CF-5, 6	K100-B3600	5
CF-7, 8	K150-B3600	5

Cable Group	Solder-Clamp (Semi-Rigid Cable)	
	Captive Contact	
	Part Number	Figure
SR-5	Contact Factory	1
SR-6	Contact Factory	1

- See page 15 for cable groups. Most types available for other cables not shown above.
- All items have nickel-plated bodies and gold-plated contacts (solder-clamp types also have gold-plated solder ferrules). All items are also available with silver-plated bodies.
- *Available in MIL-PRF-39012/17 QPL version.
- †Available as UG type.

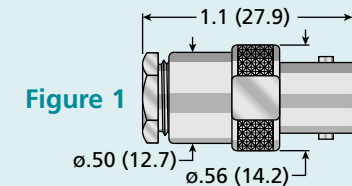

Figure 1

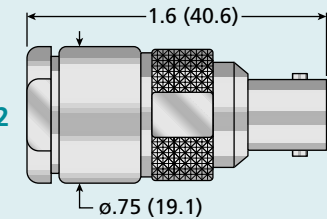

Figure 2

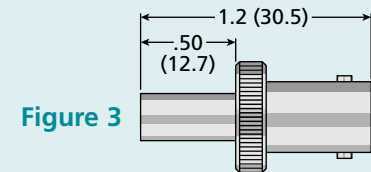

Figure 3

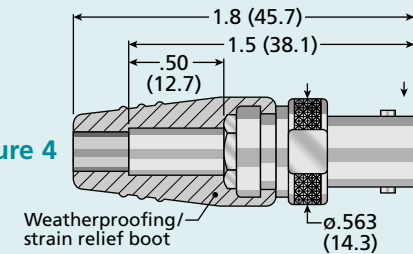

Figure 4

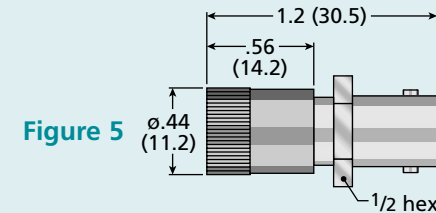

Figure 5



Straight Bulkhead Mounted Cable Jacks—Rear Mount (Mounting nut in front of panel)

Cable Group	Wedge-Lock and V-Groove				
	Wedge-Lock		V-Groove		Figure
	Standard	Improved	Non-Captive Contact	Captive Contact	
CF-1	K801-B3800B-75	10-18001-019	K011-B3000-75	K011-B3100A-75	1
CF-2	K819-B3800B-75	10-18001-016	K025-B3000-75	K025-B3100A-75	1
CF-3, 4	K847-B3800B-75	10-18001-021	K039-B3000-75	K039-B3100A-75	1
CF-5, 6	K101-B3800B-75	10-18001-022*	K100-B3000-75†	10-18004-008*	1
CF-7, 8	K151-B3800B-75	10-18001-024*	K150-B3000-75	10-18004-009*	1
CF-9	K121-B3800B-75	10-18001-023*	K120-B3000-75	K121-B3100A-75	1
CF-22	K301-B3800B-90	10-18001-026	K300-B3000-90	K301-B3100A-90	2
CF-36	K825-B3800B-75	10-18001-020	K825-B3000-75	K825-B3100A-75	1

Cable Group	Econo-Crimp and X-Crimp				
	Econo-Crimp		Figure	X-Crimp	Figure
	Non-Captive Contact	Captive Contact			
CF-2	K919-B3900S-75	10-18014-000	3	K919-B3900F-75	4
CF-3, 4	K947-B3900S-75	10-18007-012*	3	K947-B3900F-75	4
CF-5	K980-B3900-75	10-18007-014*	3	K980-B3900F-75	4
CF-6	K988-B3900-75	10-18007-015*	3	K988-B3900F-75	4
CF-7	K998-B3900-75	10-18007-016*	3	K998-B3900F-75	4
CF-8	K999-B3900-75	10-18007-012*	3	K999-B3900F-75	4
CF-9	K958-B3900-75	10-18007-017*	3	K958-B3900F-75	4
CF-36	K925-B3900S-75	10-18014-001	3	K925-B3900F-75	4

Cable Group	Solder-Clamp (Semi-Rigid Cable)	
	Captive Contact	
	Part Number	Figure
SR-5	Contact Factory	1
SR-6	Contact Factory	1

Cable Group	Wedge-Eze	
	Non-captive Contact	
	Part Number	Figure
CF-5, 6	K100-B3600-75	5
CF-7, 8	K150-B3600-75	5

- See page 15 for cable groups. Most types available for other cables not shown above.
- See page 16 for mounting hole dimensions.
- All items have nickel-plated bodies and gold-plated contacts (solder-clamp types also have gold-plated solder ferrules). All items are also available with silver-plated bodies.
- *Available in MIL-PRF-39012/19 QPL version.
- †Available as UG type.

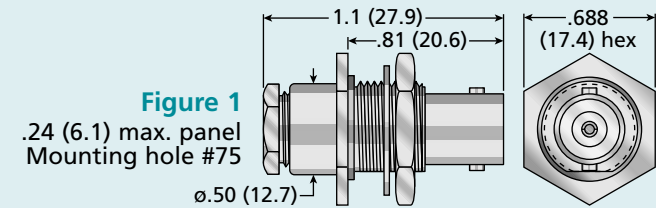

Figure 1
.24 (6.1) max. panel
Mounting hole #75

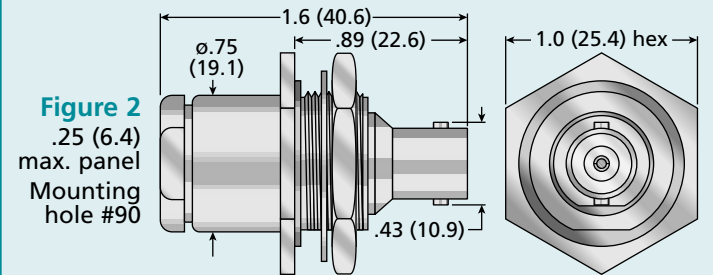

Figure 2
.25 (6.4)
max. panel
Mounting hole #90

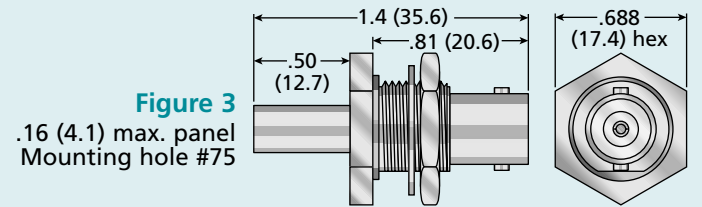

Figure 3
.16 (4.1) max. panel
Mounting hole #75

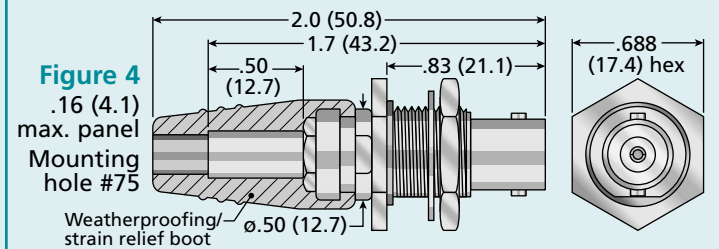

Figure 4
.16 (4.1)
max. panel
Mounting hole #75

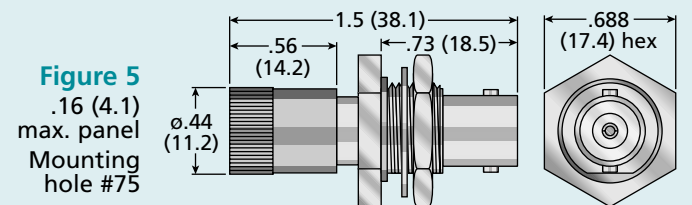

Figure 5
.16 (4.1)
max. panel
Mounting hole #75

Bulkhead Mounted Cable Jacks—Front Mount and Right Angle

Cable Group	Front Mount—Wedge-Lock and V-Groove				
	Wedge-Lock		V-Groove		Figure
	Standard	Improved	Non-Captive Contact	Captive Contact	
CF-1	K801-B3800-81	K801-B3800B-81	K011-B3000-81	K011-B3100-81	1
CF-2	K819-B3800-81	K819-B3800B-81	K025-B3000-81	K025-B3100-81	1
CF-3, 4	K847-B3800-81	K847-B3800B-81	K039-B3000-81	K039-B3100-81	1
CF-5, 6	K101-B3800-81	K101-B3800B-81	K100-B3000-81	K101-B3100-81	1
CF-7, 8	K151-B3800-81	K151-B3800B-81	K150-B3000-81	K151-B3100-81	1
CF-9	K121-B3800-81	K121-B3800B-81	K120-B3000-81	K121-B3100-81	1
CF-36	K825-B3800-81	K825-B3800B-81	K825-B3000-81	K825-B3100-81	1

Cable Group	Front Mount—X-Crimp	
	Captive Contact	
	Part Number	Figure
CF-2	K919-B3900F-81	1
CF-5	K980-B3900F-81	1
CF-6	K988-B3900F-81	1
CF-7	K998-B3900F-81	1

Cable Group	Right Angle—Wedge-Lock and V-Groove			
	Wedge-Lock		V-Groove	
	Standard	Improved	Captive Contact	Figure
CF-1	K801-B4800-75	K801-B4800B-75	K011-B4100A-75	3
CF-2	K819-B4800-75	K819-B4800B-75	K025-B4100A-75	3
CF-3, 4	K847-B4800-75	K847-B4800B-75	K039-B4100A-75	3
CF-5, 6	K101-B4800-75	K101-B4800B-75	K101-B4100A-75	3
CF-7, 8	K151-B4800-75	K151-B4800B-75	K151-B4100A-75	3
CF-9	K121-B4800-75	K121-B4800B-75	K121-B4100A-75	3
CF-36	K825-B4800-75	K825-B4800B-75	K825-B4100A-75	3

Cable Group	Solder-Clamp (Semi-Rigid Cable)			
	Captive Contact			
	Front Mount	Figure	Right Angle	Figure
SR-5	Contact Factory	1	Contact Factory	3
SR-6	Contact Factory	1	Contact Factory	3

- See page 15 for cable groups. Most types available for other cables not shown above.
- See page 16 for mounting hole dimensions.
- All items have nickel-plated bodies and gold-plated contacts (solder-clamp types also have gold-plated solder ferrules). All items are also available with silver-plated bodies.

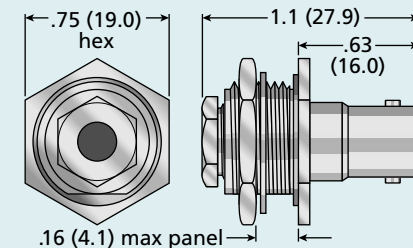

Figure 1
.16 (4.1) max. panel • Mounting hole #81

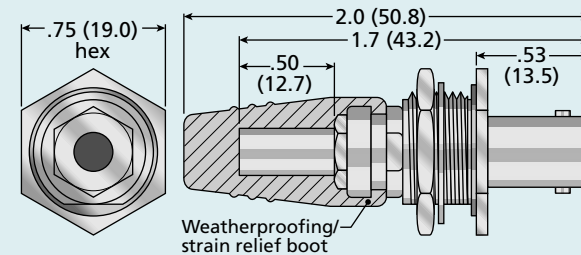

Figure 2
.16 (4.1) max. panel • Mounting hole #81

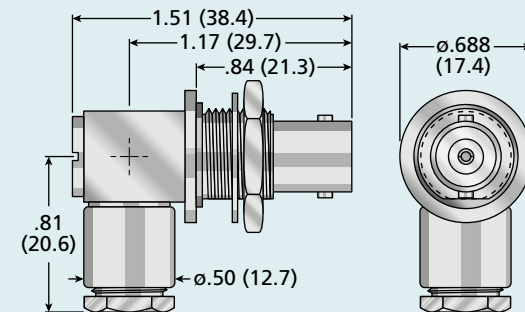

Figure 3
.19 (4.8) max. panel • Mounting hole #75

Bulkhead Mounted Cable Jacks— Pressurized

Cable Group	Straight Rear Mount—Wedge-Lock and V-Groove				
	Wedge-Lock		V-Groove		Figure
	Standard	Improved	Non-Captive Contact	Captive Contact	
CF-1	K801-B3801-75	K801-B3801B-75	K011-B3001-75	K011-B3101A-75	1
CF-2	K819-B3801-75	K819-B3801B-75	K025-B3001-75	K025-B3101A-75	1
CF-3, 4	K847-B3801-75	K847-B3801B-75	K039-B3001-75	K039-B3101A-75	1
CF-5, 6	K101-B3801-75	K101-B3801B-75	K100-B3001-75	K101-B3101A-75	1
CF-7, 8	K151-B3801-75	K151-B3801B-75	K150-B3001-75	K151-B3101A-75	1
CF-9	K121-B3801-75	K121-B3801B-75	K120-B3001-75	K121-B3101A-75	1
CF-22	K301-B3801D-75	K301-B3801Y-75	K300-B3001-75	K301-B3101A-75	2
CF-36	K825-B3801-75	K825-B3801B-75	K825-B3001-75	K825-B3101A-75	1

Cable Group	Right Angle—Wedge-Lock and V-Groove			
	Wedge-Lock		V-Groove	Figure
	Standard	Improved	Captive Contact	
CF-1	K801-B4801-75	K801-B4801B-75	K011-B4101A-75	3
CF-2	K819-B4801-75	K819-B4801B-75	K025-B4101A-75	3
CF-3, 4	K847-B4801-75	K847-B4801B-75	K039-B4101A-75	3
CF-5, 6	K101-B4801-75	K101-B4801B-75	K101-B4101A-75	3
CF-7, 8	K151-B4801-75	K151-B4801B-75	K151-B4101A-75	3
CF-9	K121-B4801-75	K121-B4801B-75	K121-B4101A-75	3
CF-36	K825-B4801-75	K825-B4801B-75	K825-B4101A-75	3

Cable Group	Solder-Clamp (Semi-Rigid Cable)			
	Captive Contact			
	Straight	Figure	Right Angle	Figure
SR-5	Contact Factory	1	Contact Factory	3
SR-6	Contact Factory	1	Contact Factory	3

- See page 15 for cable groups. Most types available for other cables not shown above.
- See page 16 for mounting hole dimensions.
- All items have nickel-plated bodies and gold-plated contacts (solder-clamp types also have gold-plated solder ferrules). All items are also available with silver-plated bodies.

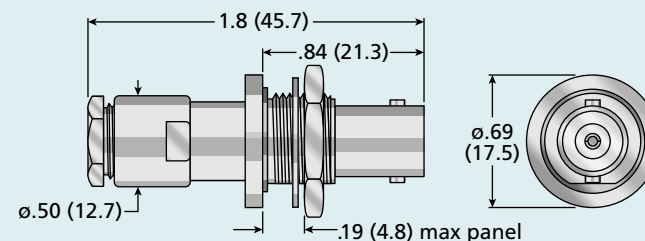

Figure 1

.19 (4.8) max. panel • Mounting hole #75

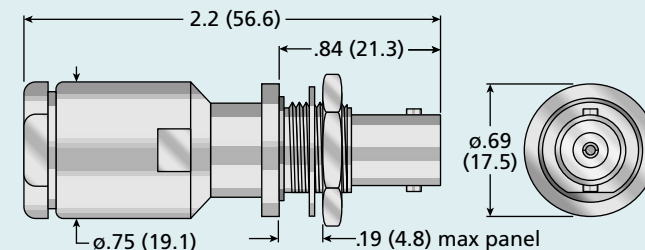

Figure 2

.19 (4.8) max. panel • Mounting hole #75

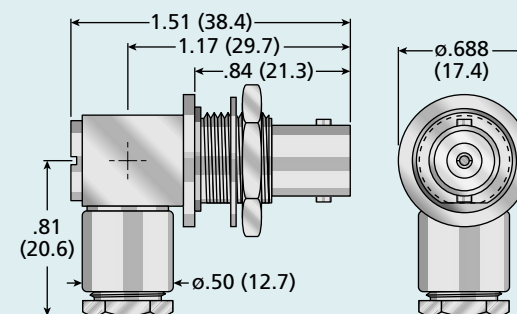

Figure 3

.19 (4.8) max. panel • Mounting hole #75

Straight Panel Mounted Cable Jacks

Cable Group	Wedge-Lock and V-Groove				Figure
	Wedge-Lock		V-Groove		
	Standard	Improved	Non-Captive Contact	Captive Contact	
CF-1	K801-B3800-10	10-19001-007	K011-B3000A-10	K011-B3100A-10	1
CF-2	K819-B3800-10	10-19001-008	K025-B3000A-10	K025-B3100A-10	1
CF-3, 4	K847-B3800-10	10-19001-010	K039-B3000A-10	K039-B3100A-10	1
CF-5, 6	K101-B3800-10	10-19001-011*	K100-B3000A-10†	10-19002-005*	1
CF-7, 8	K151-B3800-10	10-19001-013*	K150-B3000A-10†	10-19002-006*	1
CF-9	K121-B3800-10	10-19001-012*	K120-B3000A-10†	K121-B3100A-10*	1
CF-22	K301-B3800-20	10-19001-015	K300-B3000A-20	K301-B3100A-20	2
CF-36	K825-B3800-10	10-19001-009	K825-B3000A-10	K825-B3100A-10	1

Cable Group	Econo-Crimp and X-Crimp				
	Econo-Crimp		Figure	X-Crimp	
	Non-Captive Contact	Captive Contact		Figure	Figure
CF-2	K919-B3900S-10	10-19005-002	3	K919-B3900F-10	4
CF-3, 4	K947-B3900S-10	10-19004-010*	3	K947-B3900F-10	4
CF-5	K980-B3900-10	10-19004-012*	3	K980-B3900F-10	4
CF-6	K988-B3900-10	10-19004-013*	3	K988-B3900F-10	4
CF-7	K998-B3900-10	10-19004-014*	3	K998-B3900F-10	4
CF-8	K999-B3900-10	10-19004-015*	3	K999-B3900F-10	4
CF-9	K958-B3900-10	10-19004-011*	3	K958-B3900F-10	4
CF-36	K925-B3900S-10	10-19005-003	3	K925-B3900F-10	4

Cable Group	Solder-Clamp (Semi-Rigid Cable)	
	Captive Contact	
	Part Number	Figure
SR-5	Contact Factory	1
SR-6	Contact Factory	1

Cable Group	Wedge-Eze	
	Non-captive Contact	
	Part Number	Figure
CF-5, 6	K100-B3600-10	5
CF-7, 8	K150-B3600-10	5

- See page 15 for cable groups. Most types available for other cables not shown above.
- All items available with other flange sizes (see page 16).
- All items have nickel-plated bodies and gold-plated contacts (solder-clamp types also have gold-plated solder ferrules). All items are also available with silver-plated bodies.
- *Available in MIL-PRF-39012/18 QPL version.
- †Available as UG type.

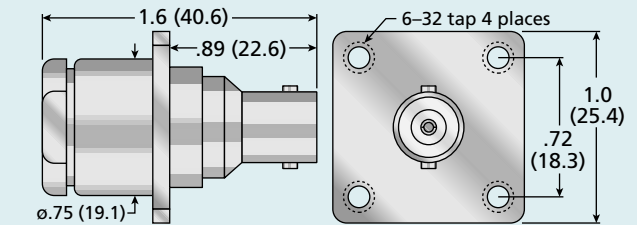
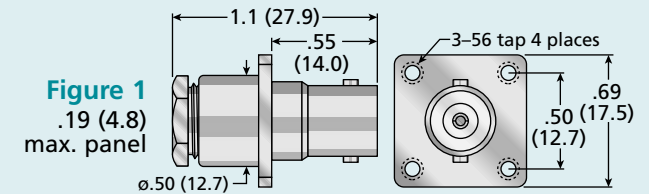

Figure 2 .19 (4.8) max. panel

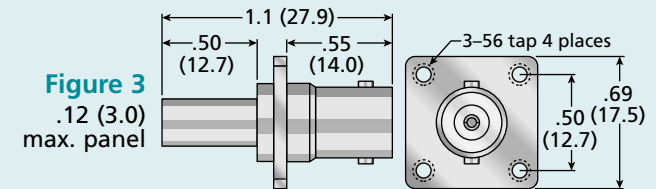

Figure 3 .12 (3.0) max. panel

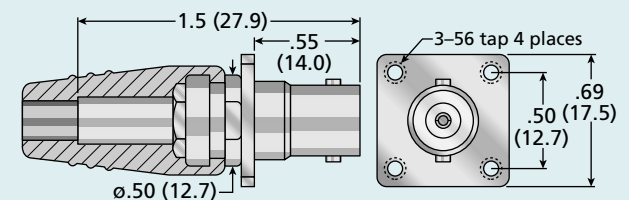

Figure 4 .19 (4.8) max. panel

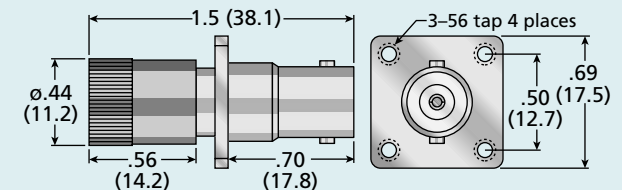

Figure 5 .25 (6.4) max. panel



Bulkhead Mounted Receptacles

Jack Receptacles

Figure	Mounting	Dim. A	Dim. B	Max. Panel	Part Number
1	60	1.19 (30.2)	.47 (11.9)	.26 (6.6)	10-46001-006*†
1	70	1.06 (26.9)	.47 (11.9)	.13 (3.3)	10-46003-004*†
1	70	1.19 (30.5)	.47 (11.9)	.26 (6.6)	10-46003-003*
2	62	1.30 (33.0)	.59 (15.0)	.16 (4.1)	10-49000-003†
3	60	1.16 (29.5)	.41 (10.4)	.26 (6.6)	10-46001-006
3	65	1.03 (26.2)	.40 (10.2)	.13 (3.3)	10-54000-003
3	65	1.16 (30.5)	.41 (10.4)	.26 (6.6)	10-54000-004*†
3	70	1.03 (26.2)	.40 (10.2)	.13 (3.3)	10-52002-001*†
4	60	1.21 (30.7)	.52 (13.2)	.28 (7.1)	10-49001-001
4	65	1.21 (30.7)	.52 (13.2)	.28 (7.1)	10-49003-001*†
4	65	1.21 (30.7)	.52 (13.2)	.31 (7.9)	10-49003-000†
5	75	1.22 (31.0)	.85 (21.6)	.19 (4.8)	10-50000-002*†
6	75	1.06 (26.9)	.50 (12.7)	.14 (3.6)	10-46014-000

Plug Receptacles

Figure	Mounting	Dim. A	Dim. B	Max. Panel	Part Number
7	60	1.2 (30.5)	.63 (16.0)	.09 (2.3)	10-32001-001

- See page 16 for mounting hole dimensions.
- All items have nickel-plated bodies and gold-plated contacts.
All items are also available with silver-plated bodies.
- *Available in MIL-PRF-39012/21 QPL version.
- †Available as UG type.

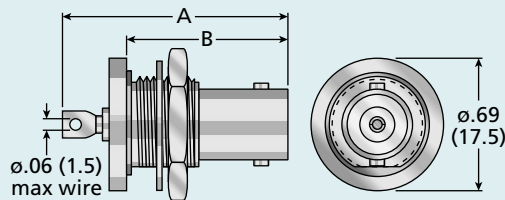
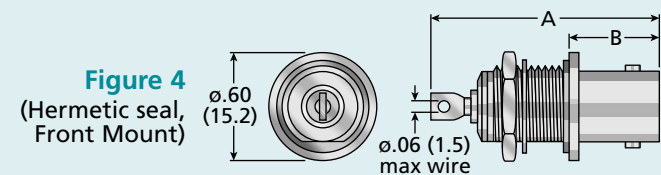
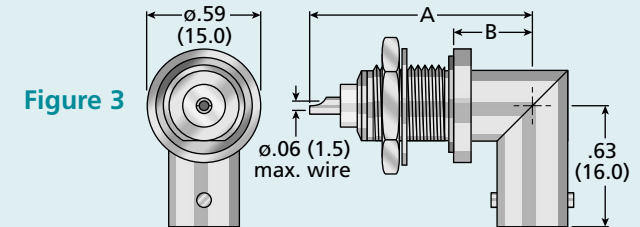
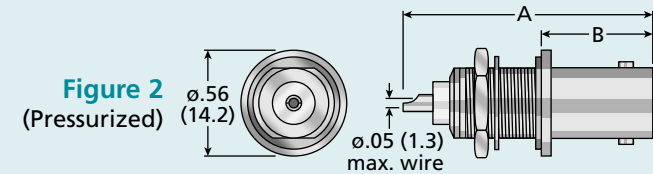
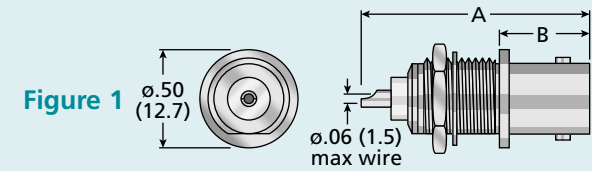

Figure 5 (Hermetic seal, Rear Mount)

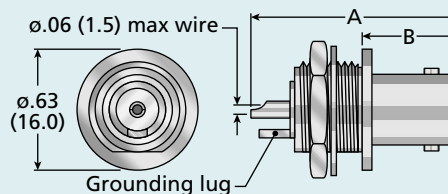

Figure 6 (Isolated Ground)

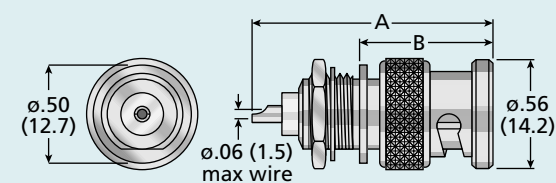
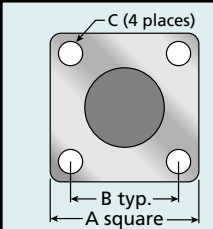

Figure 7

Panel and Printed-Circuit Board Receptacles

Panel Jack Receptacles			
Figure	Flange	Max. Panel	Part Number
1	10	.20 (5.1)	10-48000-008*†
1	11	.20 (5.1)	10-48000-009
1	13	.20 (5.1)	10-48000-010
1	14	.20 (5.1)	10-48000-011
1	15	.20 (5.1)	10-48007-000
2	10	.20 (5.1)	K10-B3100
2	11	.20 (5.1)	K11-B3100
2	13	.20 (5.1)	K13-B3100
2	14	.20 (5.1)	K14-B3100
2	15	.20 (5.1)	K15-B3100
3	10	.12 (3.0)	10-55000-003
3	15	.12 (3.0)	10-55000-004†

Panel Plug Receptacles			
Figure	Flange	Max. Panel	Part Number
4	10	.12 (3.0)	10-34000-000
4	15	.12 (3.0)	10-34001-000†

	Flange Sizes			
	Flange #	A	B	C
10	.69 (17.5)	.50 (12.7)	3-56 tap	
11	.69 (17.5)	.50 (12.7)	ø.11 (2.8)	
13	.69 (17.5)	.50 (12.7)	ø.125 (3.2)	
14	.69 (17.5)	.50 (12.7)	ø.14 (3.6)	
15	.75 (19.1)	.53 (14.0)	ø.13 (3.3)	

- All are available with other flange sizes (see page 16).
- All items have nickel-plated bodies and gold-plated contacts; also available with silver-plated bodies.
- *Available in MIL-PRF-39012/22 QPL version. †Available as UG type.

P.C. B. Jack Receptacles			
Figure	Dim. A	Max. board	Part Number
5	.125 (3.2)	.063 (1.6)	10-63000-006
5	.250 (6.4)	.125 (3.2)	10-63000-007
6	.150 (6.4)	.063 (1.6)	10-64002-002

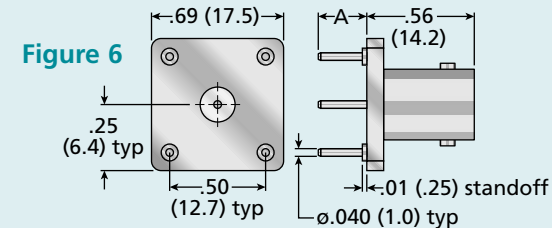
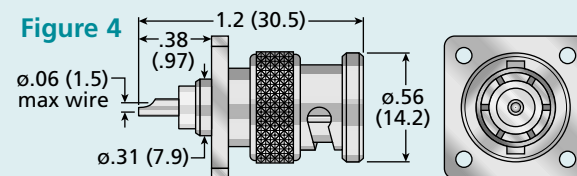
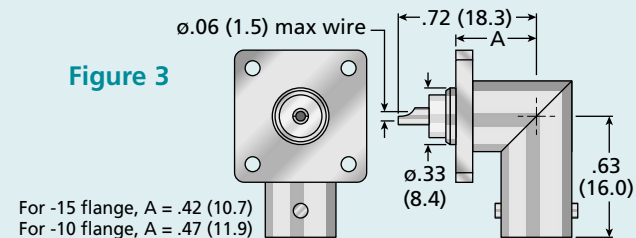
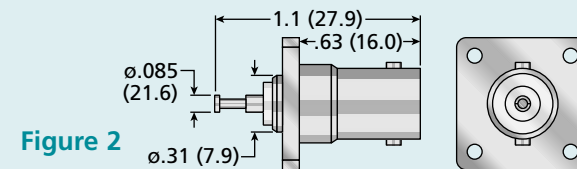
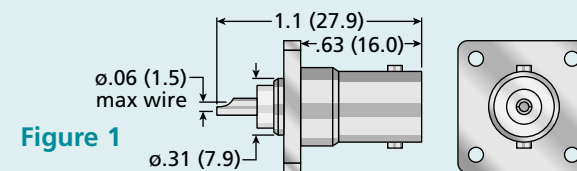
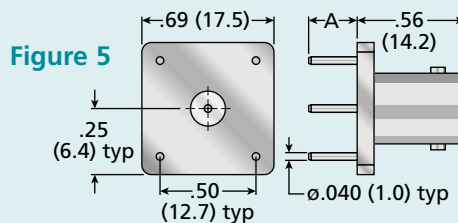



Dust Caps and Resistor Terminations

Dust Caps				
Figure	Mating	Dim. A	Chain	Part Number
1	Plug	2.0 (50.8)	Bead	10-92000-000
1	Plug	2.5 (63.5)	Bead	10-94000-002*
1	Plug	—	None	10-2002-001
2	Plug	2.4 (61.0)	Safety	10-92001-003
3	Jack	3.0 (76.2)	Bead	10-93000-001

- All items have nickel-plated bodies and gold-plated contacts. All items are also available with silver-plated bodies.

All caps are available in MIL-PRF-39012/25 QPL version , or CW- version.

*Shorting type.

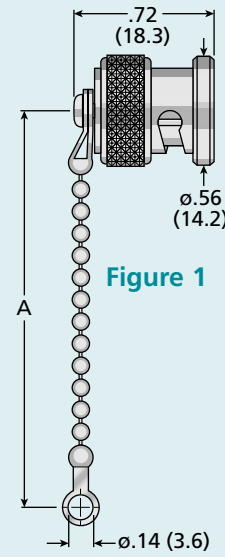

Figure 1

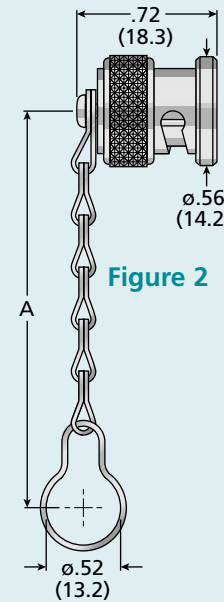

Figure 2

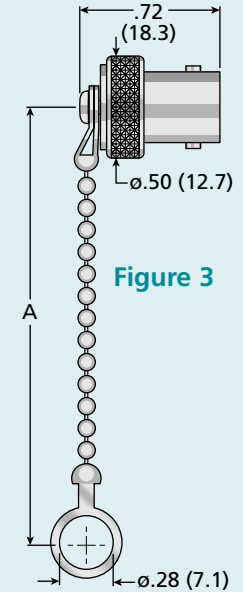

Figure 3

Resistor Terminations					
Figure	Mating	Resistor	Dim A	Chain	Part Number
4	Plug	51 ohm, 1/2W, 5%	3.5 (88.9)	Bead	10-87000-002
4	Plug	51 ohm, 2W, 2%	3.5 (88.9)	Bead	10-87003-000
4	Plug	51 ohm, 2W, 2%	—	None	10-87004-004
4	Plug	75 ohm, 1/2W, 5%	3.5 (88.9)	Bead	10-87000-003
4	Plug	100 ohm, 1/2W, 5%	3.5 (88.9)	Bead	10-87000-004
5	Adapter	50 ohm, 2W, 2%	—	—	10-73002-000
5	Adapter	93 ohm, 1W, 2%	—	—	10-73002-001

- All items have nickel-plated bodies and gold-plated contacts. All items are also available with silver-plated bodies.

All terminations available with other resistances.

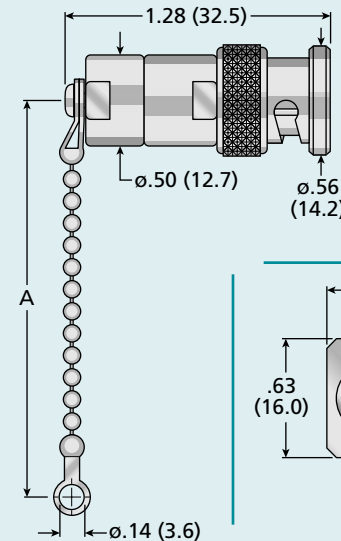

Figure 4

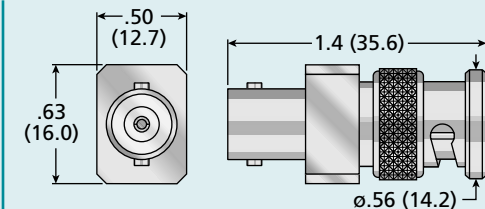

Figure 5

Adapters Within Series

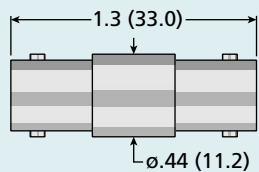

Figure 1

Figure 2

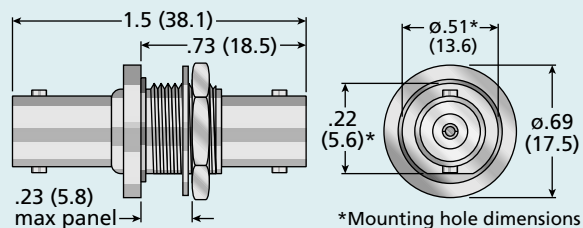
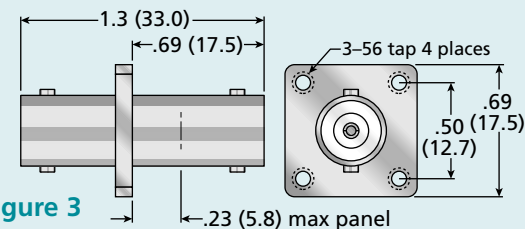

Figure 3



Straight Adapters		
Type	Figure	Part Number
Jack-Jack	1	10-68000-003*†
Jack-Jack, bulkhead mounted, hermetic	2	10-71003-003*†
Jack-Jack, panel mounted	3	10-70000-000†
Plug-Plug	4	10-68001-004*†

Right Angle Adapters		
Type	Figure	Part Number
Jack-Plug	5	10-74000-002*†
Jack-Jack, bulkhead mounted, hermetic	6	10-77000-001

Tee Adapters		
Type	Figure	Part Number
Jack-Jack-Jack	7	10-80001-001
Jack-Plug-Jack	8	10-80000-005*†
Plug-Jack-Plug	9	KB7300
Plug-Plug-Plug	10	KB7400

- All items have nickel-plated bodies and gold-plated contacts; also available with silver-plated bodies.
- *Available in MIL-PRF-55339 QPL version. †Available as UG type.

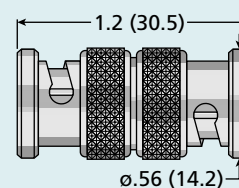

Figure 4

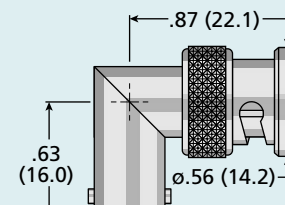

Figure 5

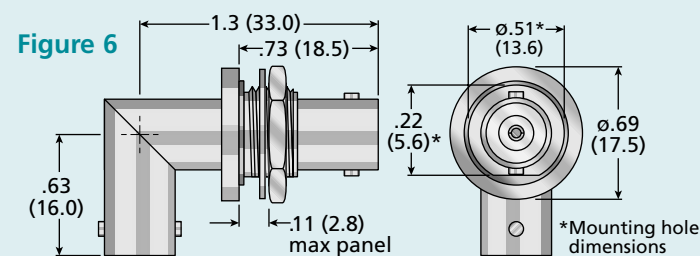

Figure 6

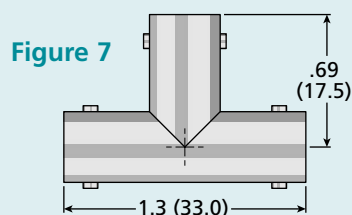

Figure 7

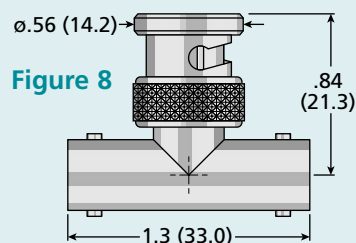

Figure 8

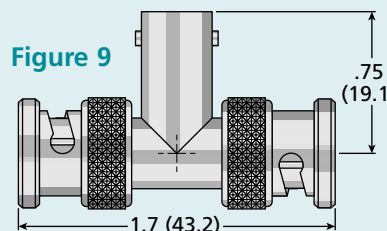

Figure 9

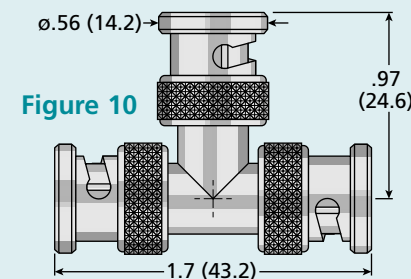

Figure 10



Cable Groups Listed by Cable Type

RG Cables*															
Type	Group	Type	Group	Type	Group	Type	Group	Type	Group	Type	Group	Type	Group	Type	Group
RG-5	CF-13	RG-21	CF-13	RG-58	CF-5	RG-94	CF-33	RG-148	CF-26	RG-180	CF-3	RG-215	CF-23	RG-303	CF-10
RG-6	CF-14	RG-22	TW-2	RG-59	CF-7	RG-108	TW-1	RG-149	CF-26	RG-187	CF-2	RG-216	CF-26	RG-304	CF-12
RG-7	CF-17	RG-30	CF-15	RG-62	CF-7	RG-115	CF-14	RG-150	CF-28	RG-188	CF-2	RG-217	CF-34	RG-307	TR-1
RG-8	CF-22	RG-31	CF-22	RG-63	CF-29	RG-115A	CF-18	RG-156	CF-25	RG-188DS	CF-36	RG-222	CF-13	RG-316	CF-2
RG-9	CF-22	RG-32	CF-23	RG-65	CF-32	RG-116	CF-23	RG-161	CF-2	RG-195	CF-4	RG-223	CF-6	RG-316DS	CF-36
RG-10	CF-23	RG-38	CF-13	RG-71	CF-8	RG-122	CF-9	RG-166	CF-23	RG-196	CF-1	RG-226	CF-35	RG-393	CF-21
RG-11	CF-26	RG-39	CF-14	RG-79	CF-29	RG-140	CF-7	RG-174	CF-2	RG-210	CF-7	RG-227	CF-23	RG-400	CF-6
RG-12	CF-28	RG-41	CF-19	RG-83	CF-20	RG-141	CF-5	RG-174DS	CF-36	RG-212	CF-13	RG-229	CF-23	RG-402	SR-6
RG-13	CF-26	RG-54	CF-15	RG-87	CF-14	RG-142	CF-6	RG-178	CF-1	RG-213	CF-22	RG-235	CF-18	RG-404	CF-1
RG-14	CF-34	RG-55	CF-6	RG-90	CF-16	RG-144	CF-26	RG-179	CF-2	RG-214	CF-22	RG-302	CF-11	RG-405	SR-5

M17 Cables**									
Type	Group	Type	Group	Type	Group	Type	Group	Type	Group
M17/2	CF-14	M17/74-RG215	CF-23	M17/119	CF-2	M17/164	CF-22	M17/184	CF-7
M17/6-RG11	CF-26	M17/75	CF-22	M17/127	CF-21	M17/165	CF-34	M17/185	CF-7
M17/6-RG12	CF-28	M17/77	CF-26	M17/128	CF-6	M17/167	CF-6	M17/186	TW-1
M17/15-RG22	TW-2	M17/78	CF-34	M17/130	SR-6	M17/168	CF-17	M17/187	CF-9
M17/28	CF-5	M17/84	CF-6	M17/132	CF-1	M17/169	CF-1	M17/188	CF-13
M17/29	CF-7	M17/90	CF-8	M17/133	SR-5	M17/170	CF-10	M17/189	CF-23
M17/30	CF-7	M17/92	CF-17	M17/138	CF-2	M17/171	CF-12	M17/190	CF-22
M17/31	CF-29	M17/93	CF-1	M17/151	SR-2	M17/172	CF-2	M17/191	CF-26
M17/45	TW-1	M17/94	CF-2	M17/152	CF-36	M17/173	CF-2	M17/194	CF-6
M17/54	CF-9	M17/95	CF-3	M17/154	SR-1	M17/174	CF-21	M17/195	CF-8
M17/60	CF-6	M17/97	CF-7	M17/155	CF-5	M17/175	CF-6	M17/196	CF-2
M17/62	CF-26	M17/110	CF-11	M17/157	CF-9	M17/180	CF-14	M17/197	CF-6
M17/65	CF-23	M17/111	CF-10	M17/158	CF-6	M17/181	CF-26	M17/198	CF-9
M17/73	CF-13	M17/112	CF-12	M17/162	CF-13	M17/182	TW-2	M17/199	CF-13
M17/74-RG213	CF-22	M17/113	CF-2	M17/163	CF-22	M17/183	CF-6	M17/200	CF-6

Semi-Rigid Cables by Jacket Diameter											
Size	Group	Size	Group	Size	Group	Size	Group	Size	Group	Size	Group
.034"	SR-1	.047"	SR-2	.056"	SR-3	.070"	SR-4	.086"	SR-5	.141"	SR-6

*Unless otherwise noted, cable groups include all variants (A/U, B/U, etc.) of RG types. 'DS' indicates double-shielded version of RG cable.

**Unless otherwise noted, cable groups include all variants of M17 slash sheet indicated.

Construction codes: CF = Coaxial, Flexible; SR = Semi-Rigid; TR = Triaxial; TW = Twinaxial

Bulkhead Mounting Hole Sizes and Flange Dimensions

Mounting Holes—Bulkhead Connectors

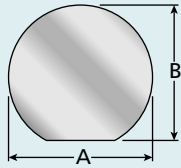
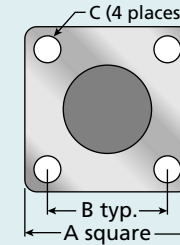

Figure	Diameter A	Dimension B
60	.390 (9.9)	.351 (8.9)
62	.390 (9.9)	.328 (8.3)
65	.406 (10.3)	.359 (9.1)
70	.437 (11.1)	.407 (10.3)
75	.515 (13.1)	.476 (12.1)
81	.640 (16.3)	.601 (15.3)
90	.765 (19.4)	.727 (18.5)

Flange Dimensions—Panel Connectors



Flange #	A	B	C
10	.69 (17.5)	.50 (12.7)	3-56 tap
11	.69 (17.5)	.50 (12.7)	ø.11 (2.8)
13	.69 (17.5)	.50 (12.7)	ø.13 (3.2)
14	.69 (17.5)	.50 (12.7)	ø.14 (3.6)
15	.75 (19.1)	.53 (14.0)	ø.13 (3.3)
20	1.00 (25.4)	.72 (18.3)	6-32 tap
25	1.00 (25.4)	.79 (20.1)	ø.13 (3.3)