



Introduction

Contents

Specifications	2
Straight Cable Plugs	3
Right Angle Cable Plugs	3
Straight Cable Jacks	4
Right Angle Cable Jacks	4
Bulkhead Cable Jacks	5
Right Angle Bulkhead Cable Jacks	5
Pressurized Bulkhead Cable Jacks	5
Panel Cable Jacks	6
Right Angle Panel Cable Jacks	6
Bulkhead Receptacles	7
Panel Receptacles	7
Accessories	8
Adapters Within Series	9

SC Interface Options

Standard Mating

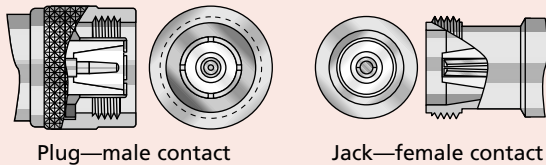

Polarized Mating

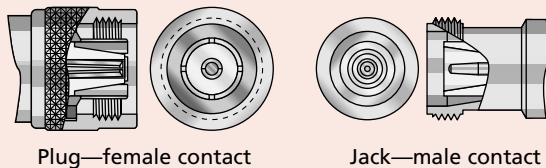

SC Coupling Nut Options

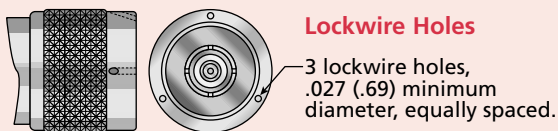

SC series connectors are general-purpose, medium connectors, with a frequency range of DC–11 GHz and 50Ω impedance, designed to MIL-PRF-39012 requirements.

Their threaded interface provides secure mating and unmating, and prevents accidental disconnection from pulling forces on the cable.

The SC cable connectors in this section have V-Groove cable clamping, but are also available with many other cable attachment types for flexible and semi-rigid cable:

- Standard and Improved **Wedge-Lock**; our patented, quick assembly method for flexible cable incorporating a captive center contact, only three parts to handle, and requiring no special tools.
- **V-Groove** clamping with captive or noncaptive contacts for flexible cable, requiring no special tools for assembly.
- **Econo-Crimp** types with captive or noncaptive contacts for flexible cable, providing small size, light weight, and rapid assembly using standard, commercially-available crimp tools.
- **X-Crimp** with captive contacts for flexible cable, providing rugged, high-strength cable attachment and quick assembly.
- **Wedge-Eze** for flexible cable is our unique system featuring quick assembly, color coding by cable size, and field replaceability. Rapidly assembled with hand or automated tooling.
- **Solder-Clamp** assembly for semi-rigid cable requires no special tools and allows for re-orientation of the connector after assembly to easily conform to system layout. Collet type clamping for solderless attachment of semi-rigid cable is also available.

See pages 11–15 for details and illustrations of all cable attachment types.

The versatility of SC series RF connectors is enhanced by Automatic's ability to provide a wide range of alternate constructions and configurations to meet virtually any system requirements. Contact us with your requirements for custom configurations, such as:

- **Polarized mating interfaces** with reversed contacts and insulators to prevent accidental mating of incompatible circuits. (see illustration at left).
- Coupling nuts can be provided with **lockwire holes** for safety wiring after mating in high-vibration applications. Hex coupling nuts are also available.
- **High-Voltage** (3,000 V, DC–2 GHz frequency range) of all configurations can be provided.
- SC connectors with **aluminum bodies** can provide significant weight savings.

Notes:

The standard SC connectors in this section have silver-plated bodies and gold-plated center contacts. All are available with other platings if required.

Drawings in this section are approximately actual size; some drawing proportions may be altered to better illustrate details.

Drawing dimensions are in inches (millimeters), based on one inch = 25.4 mm.

Interface Dimensions and Specifications

Interface Dimensions (MIL-STD-348)

Jack Interface

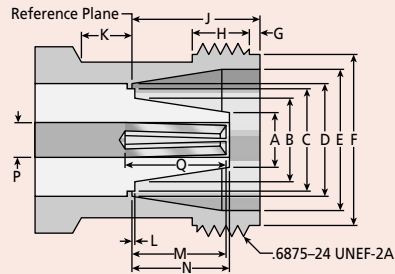

Dim.	Min.	Max.	Dim.	Min.	Max.	Dim.	Min.	Max.
A	—	.190 (4.8)	G	.047 (1.2)	.077 (2.0)	N	.303 (7.7)	.309 (7.8)
B	—	.272 (6.9)	H	.250 (6.4)	—	P	.119 (3.0)	.124 (3.1)
C	—	.374 (9.5)	J	.491 (12.5)	.495 (12.6)	Q	.300 (7.6)	—
D	.411 (10.4)	.415 (10.5)	K	.140 (3.6)	—			
E	.482 (12.2)	.489 (12.4)	L	—	.007 (.18)			
F	—	.630 (16.0)	M	.273 (6.9)	.303 (7.7)			

Plug Interface

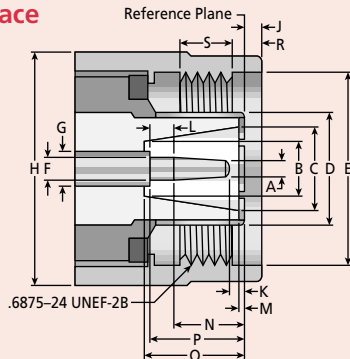

Dim.	Min.	Max.	Dim.	Min.	Max.	Dim.	Min.	Max.
A	—	.050 (1.3)	G	.119 (3.0)	.124 (3.1)	N	.191 (4.9)	.251 (6.4)
B	.194 (4.9)	—	H	—	.828 (21.0)	P	.307 (7.8)	.337 (8.6)
C	.276 (7.0)	—	J	.025 (.64)	.085 (2.2)	Q	.309 (7.8)	—
D	Gage Test	Gage Test	K	.003 (.08)	.040 (1.0)	R	.213 (5.4)	.223 (5.7)
E	.690 (17.5)	—	L	.093 (2.4)	—	S	.250 (6.4)	—
F	.090 (2.29)	.092 (2.34)	M	.007 (.18)	—			

Specifications (MIL-PRF-39012; MIL-STD-202 test methods)

Electrical:

Frequency Range: DC–11 GHz (High-voltage types DC–2 GHz). **Impedance:** 50 ohms.

Voltage Rating: 1,000 V RMS (High-voltage types 3,000 V RMS).

Insulation Resistance: 5,000 megohms min. (Method 302, condition B).

Dielectric Withstanding Voltage: 3,000 V RMS min. (Method 301).

Contact Resistance: Center Contact—1.0 milliohms max. initial; 1.5 milliohms max. after environmental tests. Outer Contact—.15 milliohms max. Braid to Body—.05 milliohms max.

RF High Potential: 2,500 V RMS min. @ 5–7.5 MHz.

VSWR: Varies with configuration; see MIL-PRF-39012 specification sheets.

RF Leakage: -90 dB min. @ 2–3 GHz.

Insertion Loss: Varies with configuration; see MIL-PRF-39012 specification sheets.

Environmental:

Vibration: Method 204, Condition B. **Shock:** Method 213, condition I.

Corona Level: 750 V min. @70,000 feet. **Temperature Range:** -65° to 165°C.

Moisture Resistance: Method 106; insulation resistance >200 megohms within 5 minutes of removal from humidity.

Thermal Shock: Method 107, condition B, high temperature 85° C.

Corrosion: Method 101, condition B.

Mechanical:

Force to Engage and Disengage: Longitudinal force, N/A.

Torque, 6 inch-pounds max.

Coupling Proof Torque: 15 inch-pounds.

Coupling Nut Retention: 100 pounds.

Cable Retention: Dependent upon cable; see MIL-PRF-39012 specification sheet.

Mating Characteristics: Per MIL-STD-348.

Durability: 500 mating cycles @ 12 cycles per minute max.

Center Contact Retention: 6–15 pounds min. axial force (captive-contact types).

Materials (unless otherwise noted):

Male Center Contacts: Brass.

Female Center Contacts, Plug Outer Contacts: Beryllium copper.

Bodies and Other Metal Parts: Brass. **Crimp Sleeves:** Annealed brass or soft copper.

Insulators: Teflon (TFE). **Gaskets:** Silicone rubber.

Plating:

Center Contacts: Gold plated per current MIL-PRF-39012 requirements.

Other Metal Parts: Silver plated per current MIL-PRF-39012 or MIL-PRF-55339 requirements.

Note: These specifications are typical, and may not apply to all configurations. Specifications may change as MIL specifications are updated.



Straight and Right Angle Cable Plugs

Cable Group	Straight Plug—V-Groove		
	Non-captive Contact	Captive Contact	Figure
CF-13	200-S1000A	201-S1100A	1
CF-14	210-S1000A	211-S1100A	1
CF-22	300-S1000A	301-S1100A	1
CF-23	302-S1000A	303-S1100A	2
CF-26	310-S1000A	311-S1100A	1
CF-28	312-S1000A	313-S1100A	2

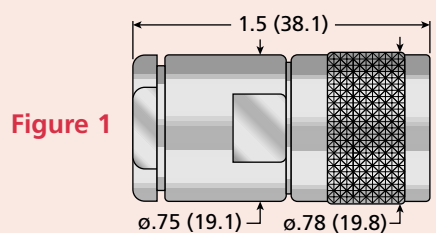

Figure 1

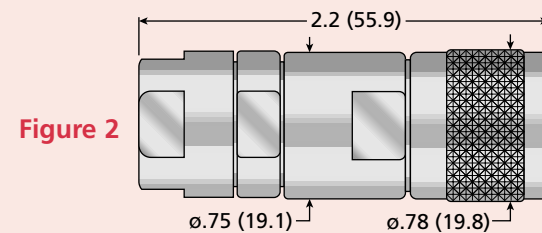

Figure 2

Cable Group	Right Angle Plug—V-Groove			
	Non-captive Contact	Figure	Captive Contact	Figure
CF-13	200-S2000N	3	201-S2100A	4
CF-14	210-S2000N	3	211-S2100A	4
CF-22	300-S2000N	3	301-S2100A	4
CF-23	302-S2000N	5	303-S2100A	6
CF-26	310-S2000N	3	311-S2100A	4
CF-28	312-S2000N	5	313-S2100A	6

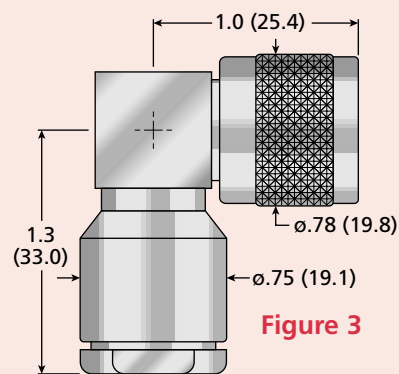

Figure 3

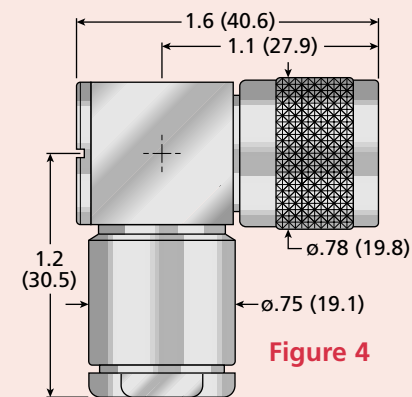

Figure 4

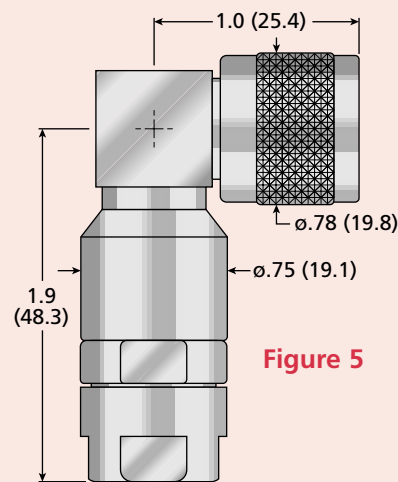

Figure 5

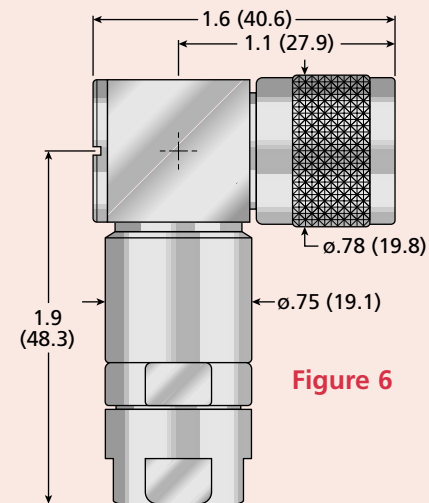

Figure 6

- All items have silver-plated bodies and gold-plated contacts. For nickel-plated body, add **K** at beginning of part number. For gold-plated body add **G** at beginning of part number.
- See page 10 for cable groups. Most types available for other cables not shown above.
- See pages 10–15 for complete descriptions and illustrations of cable attachment types.

Straight and Right Angle Cable Jacks

Cable Group	Straight Jack—V-Groove		
	Non-captive Contact	Captive Contact	Figure
CF-13	200-S3000A	201-S3100A	1
CF-14	210-S3000A	211-S3100A	1
CF-22	300-S3000A	301-S3100A	1
CF-23	302-S3000A	303-S3100A	2
CF-26	310-S3000A	311-S3100A	1
CF-28	312-S3000A	313-S3100A	2

Cable Group	Right Angle Jack—V-Groove	
	Captive Contact	Figure
CF-13	201-S4100A	3
CF-14	211-S4100A	3
CF-22	301-S4100A	3
CF-23	303-S4100A	4
CF-26	311-S4100A	3
CF-28	313-S4100A	4

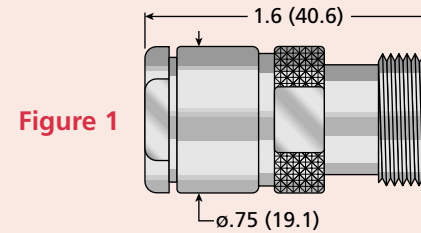

Figure 1

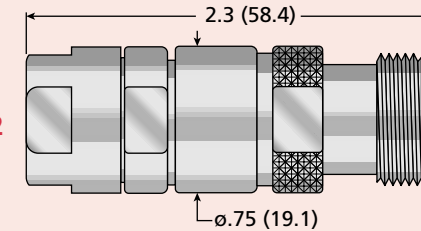

Figure 2

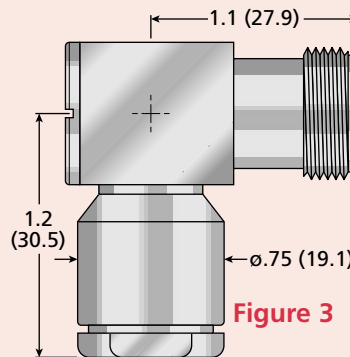

Figure 3

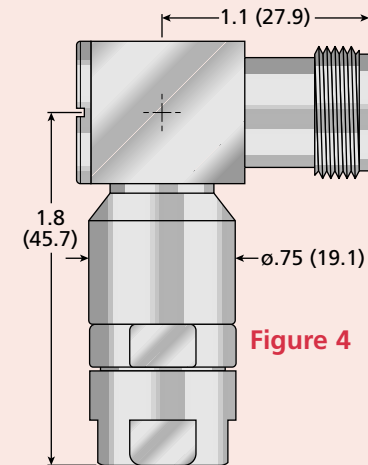

Figure 4

- All items have silver-plated bodies and gold-plated contacts. For nickel-plated body, add **K** at beginning of part number. For gold-plated body add **G** at beginning of part number.
- See page 10 for cable groups. Most types available for other cables not shown above.
- See pages 10–15 for complete descriptions and illustrations of cable attachment types.



Straight and Right Angle Bulkhead Mounted Cable Jacks

Cable Group	Straight Bulkhead Jack—V-Groove		
	Non-captive Contact	Captive Contact	Figure
CF-13	200-S3000A-90	201-S3100-90	1
	200-S3001-90*	201-S3101-90*	3
CF-14	210-S3000A-90	211-S3100-90	1
	210-S3001-90*	211-S3101-90*	3
CF-22	300-S3000A-90	301-S3100-90	1
	300-S3001-90*	301-S3101-90*	3
CF-23	302-S3000A-90	303-S3100-90	2
	302-S3001-90*	303-S3101-90*	4
CF-26	310-S3000A-90	311-S3100-90	1
	310-S3001-90*	311-S3101-90*	3
CF-28	312-S3000A-90	313-S3100-90	2
	312-S3001-90*	313-S3101-90*	4

* Pressurized.

Cable Group	Right Angle Bulkhead Jack—V-Groove	
	Captive Contact	Figure
CF-13	201-S4100A-90	5
CF-14	211-S4100A-90	5
CF-22	301-S4100A-90	5
CF-23	303-S4100A-90	6
CF-26	311-S4100A-90	5
CF-28	313-S4100A-90	6

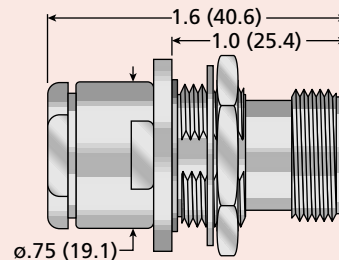

Figure 1 .09 (2.3) max. panel

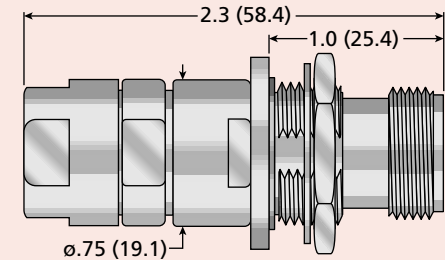

Figure 2 .09 (2.3) max. panel

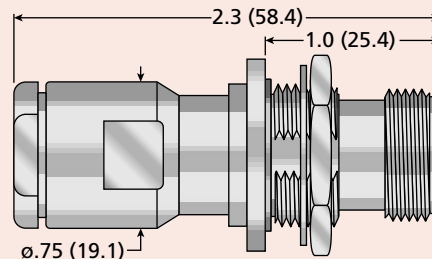

Figure 3 .09 (2.3) max. panel

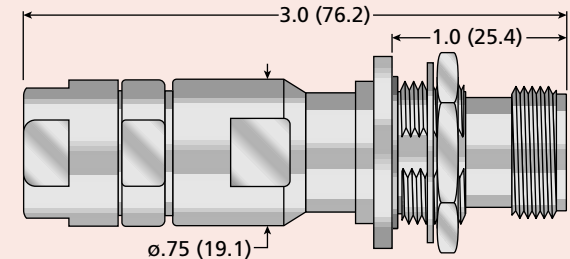
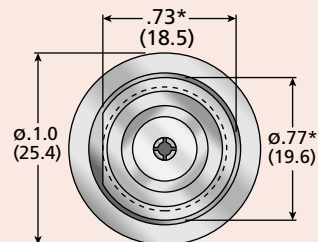

Figure 4 .09 (2.3) max. panel

Front View Typical



*Mounting hole dimensions

- All items have silver-plated bodies and gold-plated contacts. For nickel-plated body, add **K** at beginning of part number. For gold-plated body add **G** at beginning of part number.
- See page 10 for cable groups. Most types available for other cables not shown above.
- See pages 10–15 for complete descriptions and illustrations of cable attachment types.

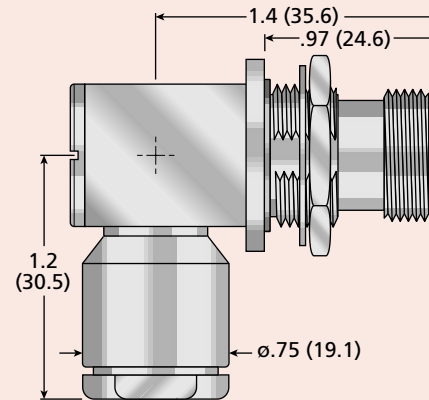

Figure 5 .16 (4.1) max. panel

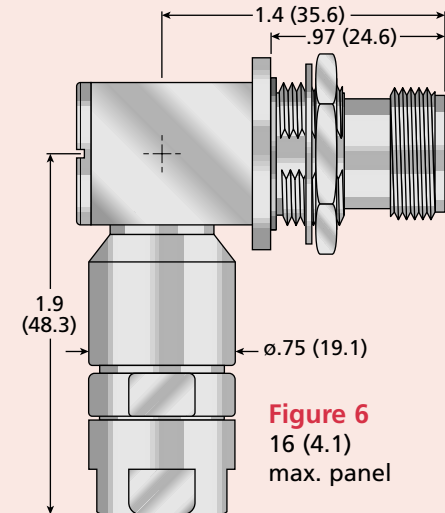

Figure 6 .16 (4.1) max. panel

Straight and Right Angle Panel Mounted Cable Jacks

Cable Group	Straight Panel Jack—V-Groove		
	Non-captive Contact	Captive Contact	Figure
CF-13	200-S3000A-20	201-S3100A-20	1
CF-14	210-S3000A-20	211-S3100A-20	1
CF-22	300-S3000A-20	301-S3100A-20	1
CF-23	302-S3000A-20	303-S3100A-20	2
CF-26	310-S3000A-20	311-S3100A-20	1
CF-28	312-S3000A-20	313-S3100A-20	2

Cable Group	Right Angle Panel Jack—V-Groove	
	Captive Contact	Figure
CF-13	201-S4100A-20	3
CF-14	211-S4100A-20	3
CF-22	301-S4100A-20	3
CF-23	303-S4100A-20	4
CF-26	311-S4100A-20	3
CF-28	313-S4100A-20	4

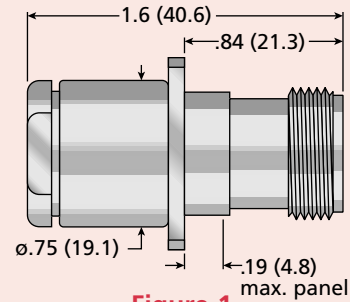

Figure 1

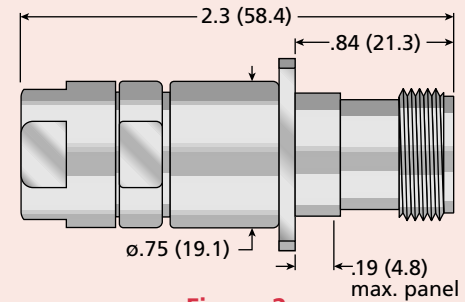

Figure 2

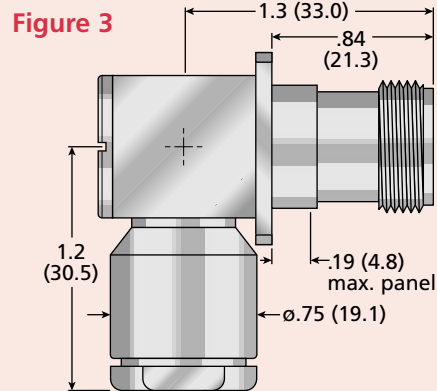

Figure 3

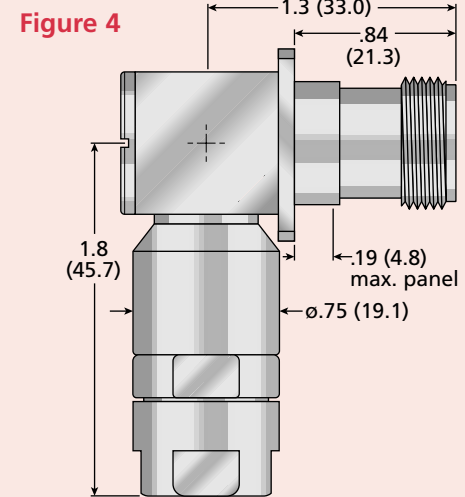
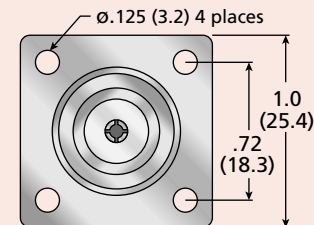

Figure 4

- All items have silver-plated bodies and gold-plated contacts. For nickel-plated body, add **K** at beginning of part number. For gold-plated body add **G** at beginning of part number.
- For flange with .125 (3.2) clearance holes, change last two digits of part number to **-25**.
- See page 10 for cable groups. Most types available for other cables not shown above.
- See pages 10–15 for complete descriptions and illustrations of cable attachment types.

Front View Typical





Bulkhead and Panel Mounted Receptacles

Rear Mount Bulkhead Receptacles

Figure	Mounting	Dim. A	Dim. B	Max. Panel	Part Number
1	90	1.3 (33.0)	.91 (23.1)	.08 (2.0)	90-S3000
2	90	1.5 (38.1)	.91 (23.1)	.08 (2.0)	90-S3501

Front Mount Bulkhead Receptacles

Figure	Mounting	Dim. A	Dim. B	Dim. C	Part Number
4	70	1.3 (33.0)	.44 (11.2)	.41 (10.4)	85-S3000
5	65	1.3 (33.0)	.41 (10.4)	.36 (9.1)	65-S3100
5	65	1.5 (38.1)	.41 (10.4)	.36 (9.1)	65-S3101*
6	65	1.5 (38.1)	.41 (10.4)	.36 (9.1)	65-S3501*
6	70	1.5 (38.1)	.44 (11.2)	.41 (10.4)	70-S3501*

Panel Jack Receptacles

Figure	Flange	Max. Panel	Part Number
6	20	.19 (4.8)	20-S3000†

Figure 1 (Rear Mount, Solder Pot Contact)

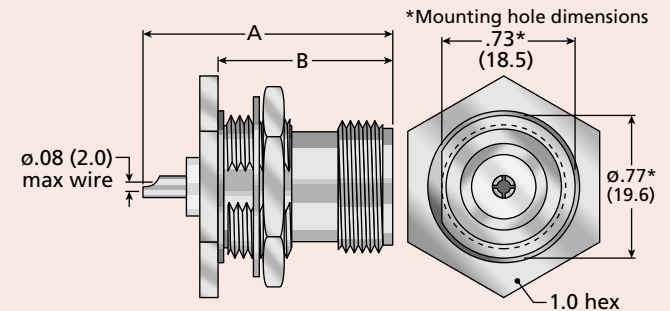

Figure 2 (Rear Mount, Flattened & Pierced Contact)

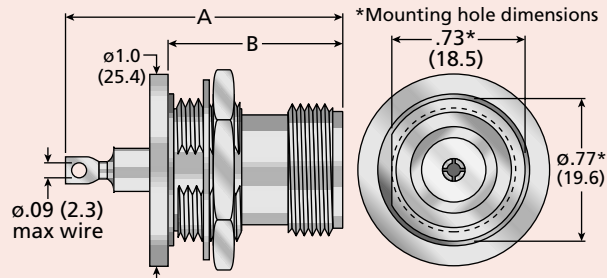

Figure 3 (Front Mount, Solder Pot Contact)

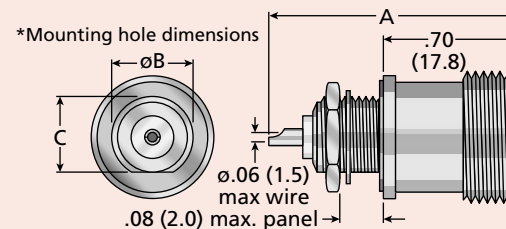

Figure 4 (Front Mount, Turret Contact)

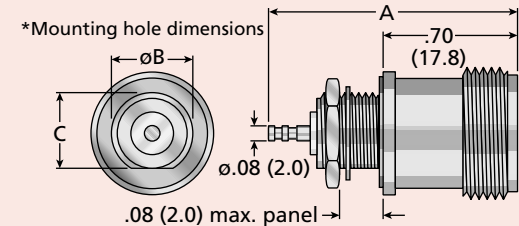

Figure 5

(Front Mount, Flattened & Pierced Contact)

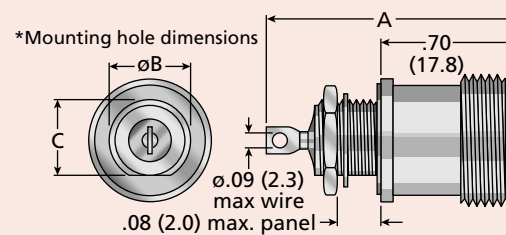
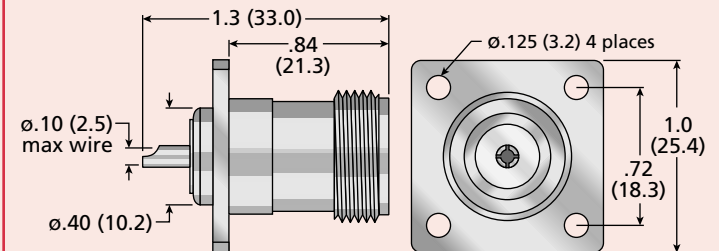

Figure 6 (Straight Panel Jack)



- All items have silver-plated bodies and gold-plated contacts. For nickel-plated body, add K at beginning of part number. For gold-plated body add G at beginning of part number.

* Hermetically sealed.

† For flange with .125 (3.2) clearance holes, change last two digits of part number to -25.

Dust Caps and Resistor Terminations

Dust Caps						
Figure	Mating	Dim. A	Dim. B	Dim. C	Chain	Part Number
1	Plug	.78 (19.8)	.144 (3.7)	2.50 (63.5)	Bead	1-S732
1	Plug	.78 (19.8)	—	—	None	1-S700
1	Plug	.78 (19.8)	.144 (3.7)	2.50 (63.5)	Bead	2-S732†
1	Plug	.78 (19.8)	—	—	None	2-S700†
2	Jack	.78 (19.8)	.144 (3.7)	3.50 (88.9)	Bead	3-S762
2	Jack	.78 (19.8)	—	—	None	3-S700
2	Jack	.78 (19.8)	.144 (3.7)	3.50 (88.9)	Bead	4-S762†
2	Jack	.78 (19.8)	—	—	None	4-S700†

- All items have silver-plated bodies.
For nickel-plated body, add K at beginning of part number.
For gold-plated body add G at beginning of part number.
- † Shorting type.

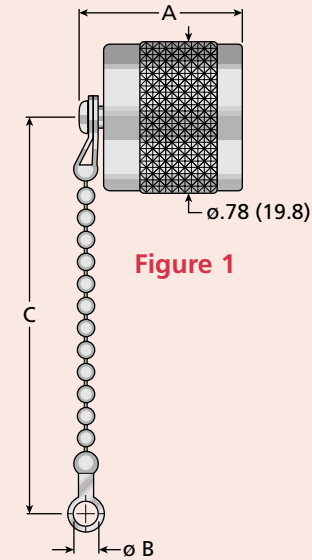

Figure 1

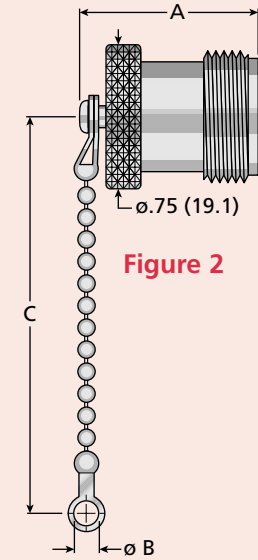

Figure 2

Resistor Terminations					
Figure	Mating	Resistor	Dim A	Chain	Part Number
3	Plug	51 ohm, 1/2W, 5%	3.50 (88.9)	Bead	5-S062-51
3	Plug	51 ohm, 1/2W, 5%	—	None	5-S000-51
3	Plug	100 ohm, 1/2W, 5%	3.50 (88.9)	Bead	5-S062-100
3	Plug	100 ohm, 1/2W, 5%	—	None	5-S000-100

Also available with other resistances.

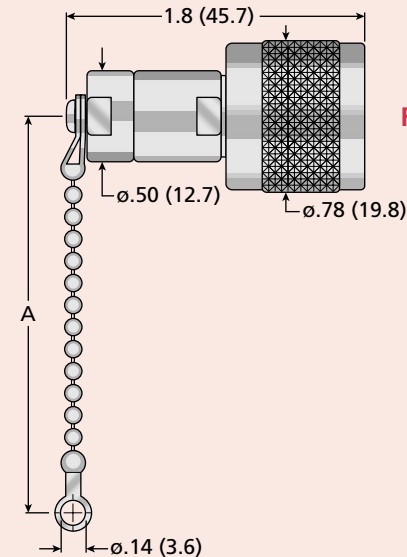
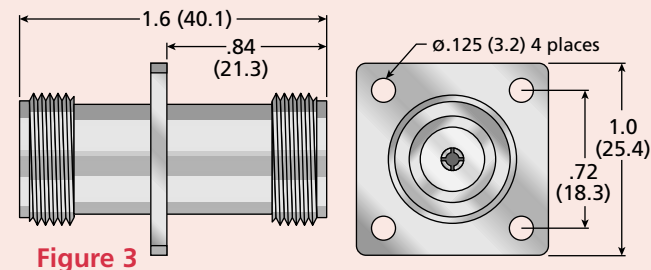
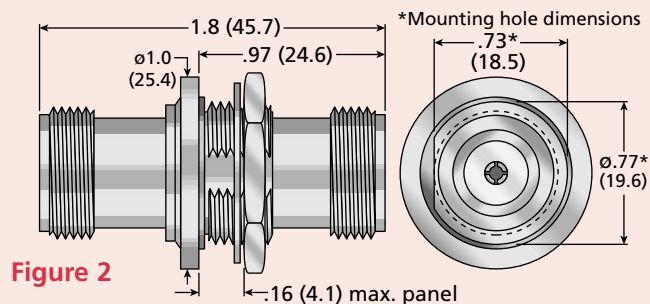
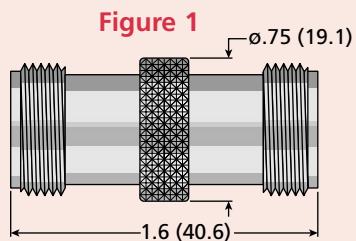

Figure 3



Adapters Within Series



Straight Adapters		
Type	Figure	Part Number
Jack-Jack	1	S3000
Jack-Jack, bulkhead, hermetic	2	S3001A-90
Jack-Jack, panel mounted	3	S3000-25
Plug-Plug	4	S1500

Right Angle Adapters		
Type	Figure	Part Number
Jack-Plug	5	S2100A

Tee Adapters		
Type	Figure	Part Number
Jack-Jack-Jack	6	S7600
Jack-Plug-Jack	7	S7200
Plug-Plug-Plug	8	S7400

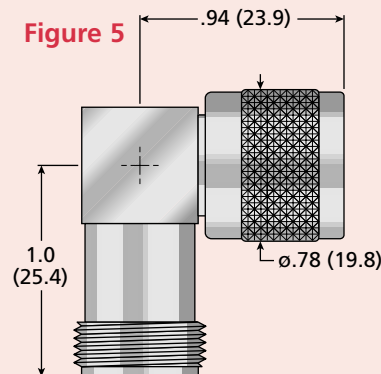
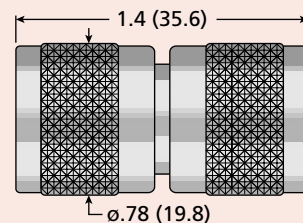

- All items have silver-plated bodies and gold-plated contacts. For nickel-plated body, add K at beginning of part number. For gold-plated body add G at beginning of part number.

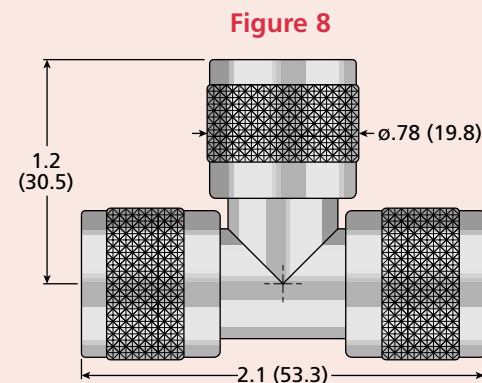
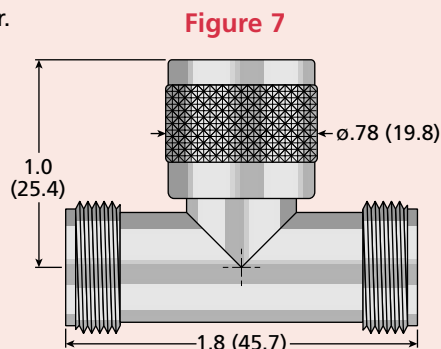
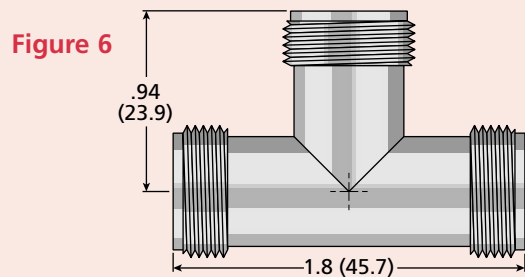



Cable Groups Listed by Cable Type

RG Cables*

Type	Group	Type	Group	Type	Group	Type	Group	Type	Group	Type	Group	Type	Group	Type	Group
RG-5	CF-13	RG-21	CF-13	RG-58	CF-5	RG-94	CF-33	RG-148	CF-26	RG-180	CF-3	RG-215	CF-23	RG-303	CF-10
RG-6	CF-14	RG-22	TW-2	RG-59	CF-7	RG-108	TW-1	RG-149	CF-26	RG-187	CF-2	RG-216	CF-26	RG-304	CF-12
RG-7	CF-17	RG-30	CF-15	RG-62	CF-7	RG-115	CF-14	RG-150	CF-28	RG-188	CF-2	RG-217	CF-34	RG-307	TR-1
RG-8	CF-22	RG-31	CF-22	RG-63	CF-29	RG-115A	CF-18	RG-156	CF-25	RG-188DS	CF-36	RG-222	CF-13	RG-316	CF-2
RG-9	CF-22	RG-32	CF-23	RG-65	CF-32	RG-116	CF-23	RG-161	CF-2	RG-195	CF-4	RG-223	CF-6	RG-316DS	CF-36
RG-10	CF-23	RG-38	CF-13	RG-71	CF-8	RG-122	CF-9	RG-166	CF-23	RG-196	CF-1	RG-226	CF-35	RG-393	CF-21
RG-11	CF-26	RG-39	CF-14	RG-79	CF-29	RG-140	CF-7	RG-174	CF-2	RG-210	CF-7	RG-227	CF-23	RG-400	CF-6
RG-12	CF-28	RG-41	CF-19	RG-83	CF-20	RG-141	CF-5	RG-174DS	CF-36	RG-212	CF-13	RG-229	CF-23	RG-402	SR-6
RG-13	CF-26	RG-54	CF-15	RG-87	CF-14	RG-142	CF-6	RG-178	CF-1	RG-213	CF-22	RG-235	CF-18	RG-404	CF-1
RG-14	CF-34	RG-55	CF-6	RG-90	CF-16	RG-144	CF-26	RG-179	CF-2	RG-214	CF-22	RG-302	CF-11	RG-405	SR-5

M17 Cables**

Type	Group	Type	Group	Type	Group	Type	Group	Type	Group
M17/2	CF-14	M17/74-RG215	CF-23	M17/119	CF-2	M17/164	CF-22	M17/184	CF-7
M17/6-RG11	CF-26	M17/75	CF-22	M17/127	CF-21	M17/165	CF-34	M17/185	CF-7
M17/6-RG12	CF-28	M17/77	CF-26	M17/128	CF-6	M17/167	CF-6	M17/186	TW-1
M17/15-RG22	TW-2	M17/78	CF-34	M17/130	SR-6	M17/168	CF-17	M17/187	CF-9
M17/28	CF-5	M17/84	CF-6	M17/132	CF-1	M17/169	CF-1	M17/188	CF-13
M17/29	CF-7	M17/90	CF-8	M17/133	SR-5	M17/170	CF-10	M17/189	CF-23
M17/30	CF-7	M17/92	CF-17	M17/138	CF-2	M17/171	CF-12	M17/190	CF-22
M17/31	CF-29	M17/93	CF-1	M17/151	SR-2	M17/172	CF-2	M17/191	CF-26
M17/45	TW-1	M17/94	CF-2	M17/152	CF-36	M17/173	CF-2	M17/194	CF-6
M17/54	CF-9	M17/95	CF-3	M17/154	SR-1	M17/174	CF-21	M17/195	CF-8
M17/60	CF-6	M17/97	CF-7	M17/155	CF-5	M17/175	CF-6	M17/196	CF-2
M17/62	CF-26	M17/110	CF-11	M17/157	CF-9	M17/180	CF-14	M17/197	CF-6
M17/65	CF-23	M17/111	CF-10	M17/158	CF-6	M17/181	CF-26	M17/198	CF-9
M17/73	CF-13	M17/112	CF-12	M17/162	CF-13	M17/182	TW-2	M17/199	CF-13
M17/74-RG213	CF-22	M17/113	CF-2	M17/163	CF-22	M17/183	CF-6	M17/200	CF-6

Semi-Rigid Cables by Jacket Diameter

Size	Group	Size	Group	Size	Group	Size	Group	Size	Group	Size	Group
.034"	SR-1	.047"	SR-2	.056"	SR-3	.070"	SR-4	.086"	SR-5	.141"	SR-6

*Unless otherwise noted, cable groups include all variants (A/U, B/U, etc.) of RG types. 'DS' indicates double-shielded version of RG cable.

**Unless otherwise noted, cable groups include all variants of M17 slash sheet indicated.

Construction codes: CF = Coaxial, Flexible; SR = Semi-Rigid; TR = Triaxial; TW = Twinaxial



Cable Attachment Types—Flexible Cable

Standard Wedge-Lock

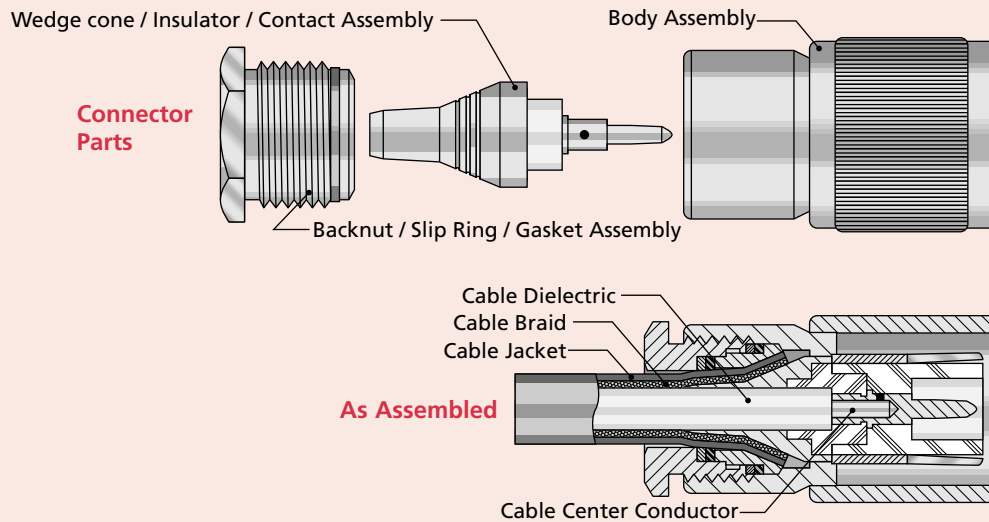

This patented attachment system features a captive contact, quick assembly, and secure cable retention. The cable braid and jacket are flared over the cone-shaped wedge, and the backnut captures the braid and jacket when screwed into the body assembly.

Unlike some similar constructions, the backnut incorporates a slip ring to prevent twisting of the cable during assembly.

Gaskets in the backnut provide weatherproofing of the cable attachment. The cable center conductor is soldered to the contact.

Many connectors with Wedge-Lock cable attachment are qualified to MIL-PRF-39012, Category A (field replaceable, no special tools required for assembly).

Improved Wedge-Lock

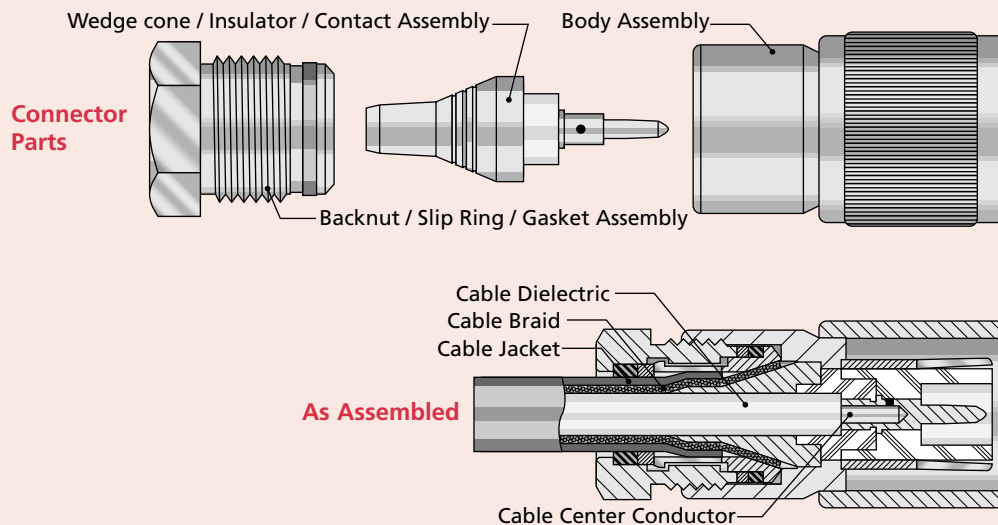

This patented attachment system features a captive contact, quick assembly, and secure cable retention. The cable braid and jacket are flared over the cone-shaped wedge, and the backnut captures the braid and jacket when screwed into the body assembly.

This construction differs from standard Wedge-Lock in that the braid is clamped directly by the nut and wedge, providing metal-to-metal contact. The cable jacket is secured in an adjacent area of the backnut assembly for weatherproofing.

Unlike some similar constructions, the backnut incorporates a slip ring to prevent twisting of the cable during assembly.

The cable conductor is soldered to the contact. Many connectors with Improved Wedge-Lock cable attachment are qualified to MIL-PRF-39012, Category A (field replaceable, no special tools required for assembly).

Cable Attachment Types—Flexible Cable

Econo-Crimp—Non-Captive Contact

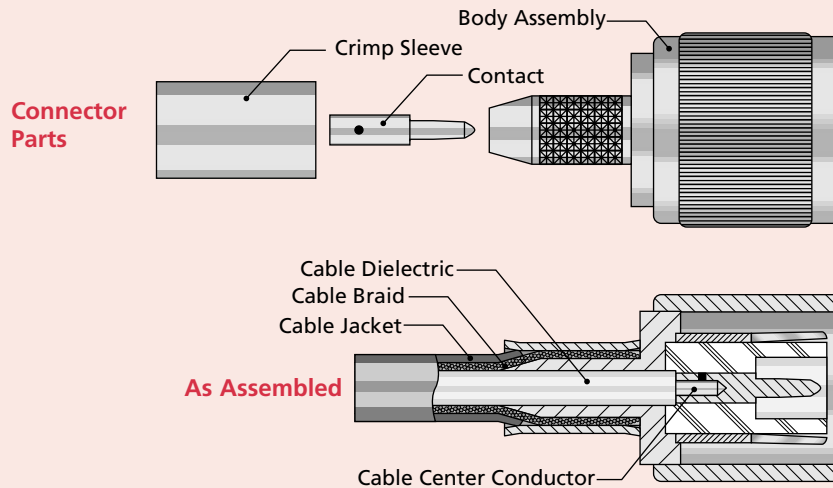

This inexpensive cable attachment method features quick assembly and small connector size and weight. The cable is stripped and the connector contact soldered to the cable center conductor. The tail of the body is inserted under the cable braid, and the crimp sleeve moved into position and crimped.

For additional savings in assembly time, some Econo-Crimp connectors have contacts that can be crimped to the conductor instead of being soldered.

All Econo-Crimp connectors use readily-available commercial crimp tools and dies for assembly.

Econo-Crimp connectors can be ordered with heat-shrinkable tubing for weatherproofing.

Econo-Crimp—Captive Contact

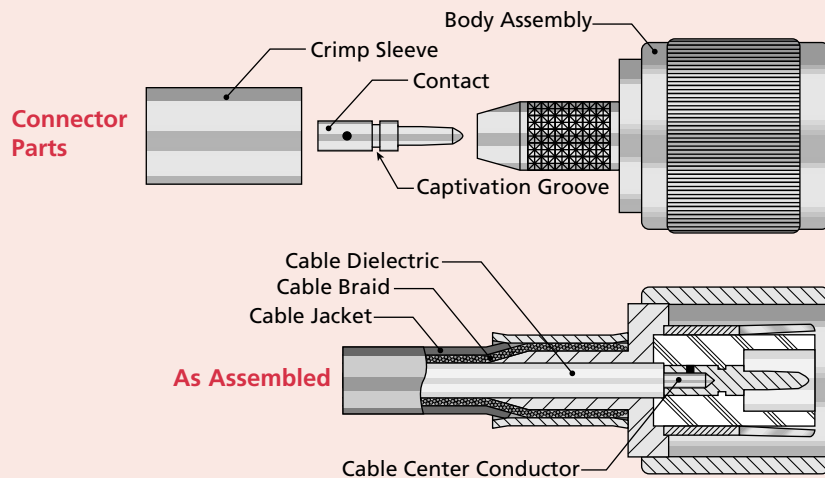

These connectors offer quick assembly time and small size, and feature a captive contact which snaps into place in the insulator when assembled. This provides consistent axial contact location within the interface, and prevents movement of the contact from cable flexure or temperature changes after assembly.

The cable is stripped and the connector contact soldered to the cable center conductor. The tail of the body is inserted under the cable braid, and the crimp sleeve moved into position and crimped.

For additional savings in assembly time, some Econo-Crimp connectors have contacts that can be crimped to the conductor instead of being soldered. All Econo-Crimp connectors use readily-available commercial crimp tools and dies for assembly.

Econo-Crimp connectors can be ordered with heat-shrinkable tubing for weatherproofing.

Many connectors with Captive Contact Econo-Crimp cable attachment are qualified to MIL-PRF-39012, Category B (non-field replaceable), Category C (MIL-defined crimp tools and cable strip dimensions), and Category D (MIL-defined contact and crimp-sleeve dimensions).



Cable Attachment Types—Flexible Cable

X-Crimp

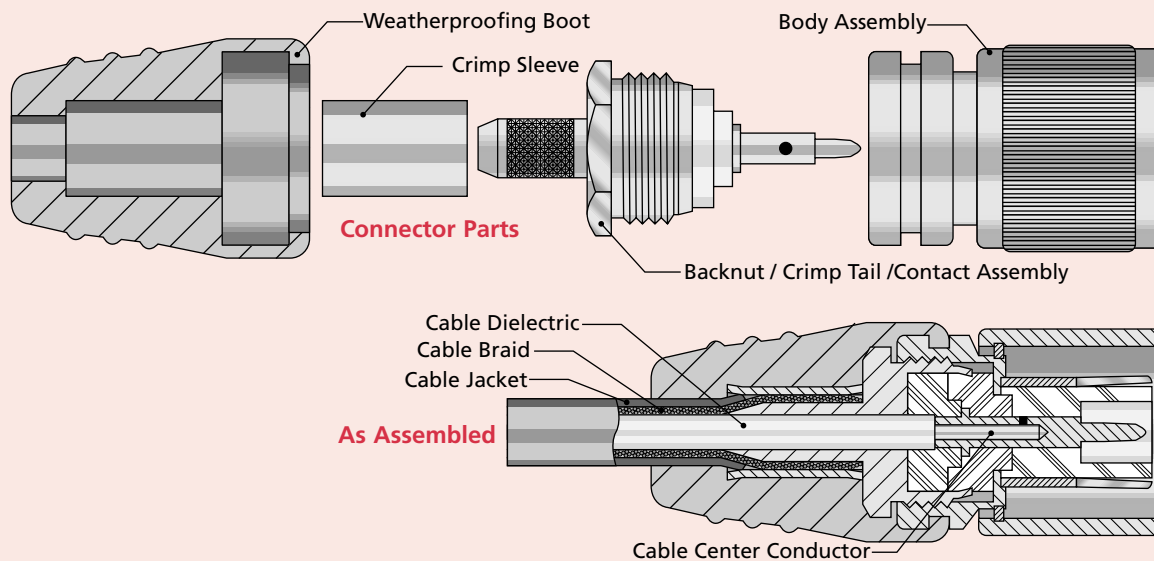

X-Crimp cable attachment combines ease of assembly with a captivated contact and a silicone-rubber boot* for weatherproofing. The captive contact is held rigidly in place to prevent movement from cable flexure or temperature changes after assembly. The cable is trimmed, and the tail of the backnut assembly is pushed under the braid. The contact is soldered to the cable conductor, the braid crimped within the crimp sleeve, and the backnut assembly screwed into the body. The boot slides forward and snaps into place. The boots can be supplied in a variety of colors for identification. Some connectors with X-Crimp cable attachment are qualified to MIL-PRF-39012, Category B (non-field replaceable), and Category C (MIL-defined crimp tools and cable stripping dimensions). *SMA and smaller size connectors use heat-shrink tubing instead of silicone-rubber boots.

Wedge-Eze

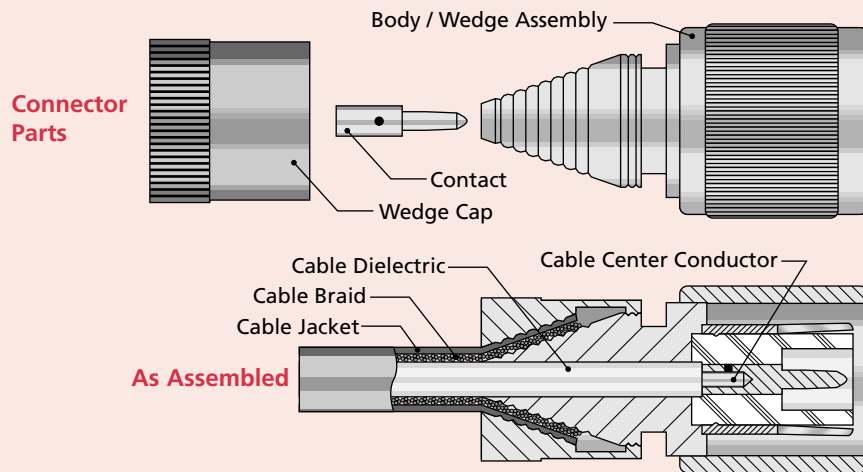

This unique attachment system provides very fast assembly and is field replaceable. The cable is stripped, and the connector contact soldered to the center conductor. The prepared cable is pushed into the body assembly, and the wedge flares the braid. The plastic wedge cap is pushed forward over the cable braid, where it locks into place. The cap can be assembled with an inexpensive hand tool or using automated equipment for large production runs. The plastic caps are can be supplied in a variety of colors for identification.



Cable Attachment Types—Flexible Cable

V-Groove—Non-Captive Contact

Connector Parts

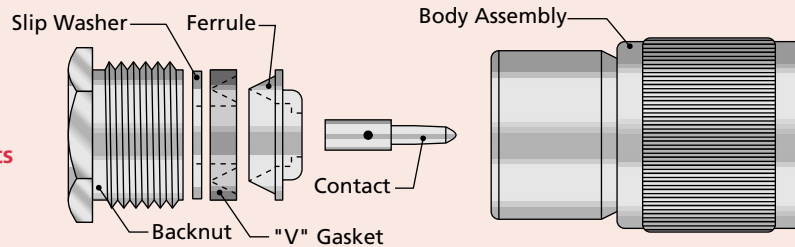

As Assembled

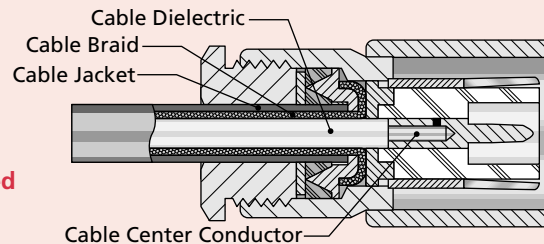

V-Groove cable attachment is the standard for military UG-type connectors, and is field-replaceable with no special tools.

The cable is stripped, and the braid is combed out and folded back over the ferrule. The connector contact is soldered to the cable conductor.

The prepared cable, the V-gasket, and the slip washer are secured in the body assembly by tightening the backnut.

The slip washer prevents twisting the cable while the nut is being tightened, and the rear surface of the ferrule cuts through the V-gasket, providing metal-to-metal braid clamping as well as weatherproofing.

V-Groove—Captive Contact

Connector Parts

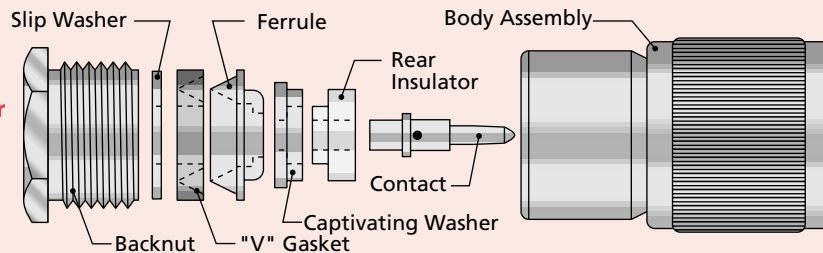

As Assembled

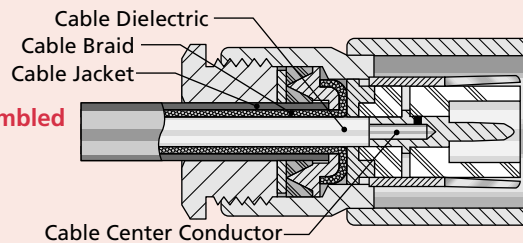

V-Groove clamping with a captive contact provides consistent axial contact location within the interface, and prevents movement of the contact from cable flexure or temperature changes after assembly.

The cable is stripped, and the braid is combed out and folded back over the ferrule. The connector contact is soldered to the cable conductor.

The prepared cable, the rear insulator and captivating washer, the V-gasket, and the slip washer are secured in the body assembly by tightening the backnut.

The slip washer prevents twisting the cable while the nut is being tightened, and the rear surface of the ferrule cuts through the V-gasket, providing metal-to-metal braid clamping as well as weatherproofing.

Many connectors with Captive Contact V-Groove cable attachment are qualified to MIL-PRF-39012, Category A (Field replaceable, no special tools required for assembly).



Cable Attachment Types—Semi-Rigid Cable

Solder-Clamp (Used on BNC and larger connectors)

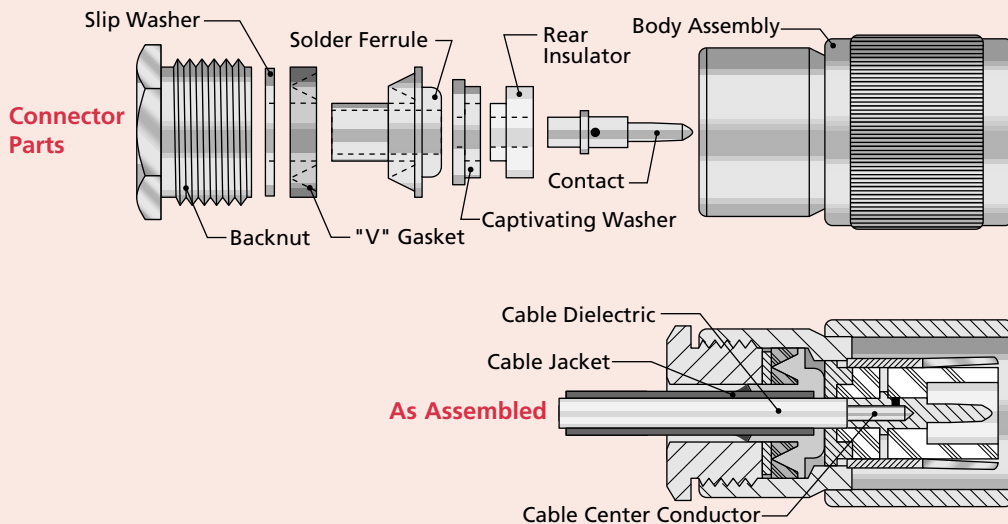

This attachment method is similar to the V-Groove type used for flexible cable, but is adapted to use with semi-rigid cable by replacing the braid-clamp ferrule with a ferrule designed to be soldered to the jacket (outer conductor) of semi-rigid cable.

This design allows right-angle or chassis-mounted connectors to be re-oriented after cable attachment to easily conform to system layout.

The cable is stripped, and the ferrule is soldered to the cable jacket before soldering the contact to the cable conductor. This allows for trimming the cable dielectric after soldering the jacket, eliminating any dielectric extrusion that may occur during jacket soldering.

Captive contacts (as shown) are highly recommended for connectors used with semi-rigid cable.